

PALUX Topline Thermal

PRICE LIST

Prices valid from 1st February 2023



PALUX

Die große Freiheit

PALUX Topline Thermal - List of Contents

	Page
PALUX Topline Thermal Overview	6
Single-Pan Deep Fat Fryer	12
PALUX Topline Thermal	12
Single-Pan Deep Fat Fryer with electronic control Plus	12
Single-Pan Deep Fat Fryer with electronic control Plus and filter system	13
Single-Pan Deep Fat Fryer with electronic control Plus, filter system and oil pump	14
Single-Pan Deep Fat Fryer with electronic control Plus, filter system and basket lift	15
Single-Pan Deep Fat Fryer with electronic control Plus, filter system, pump and basket lift	16
Dual-Pan Deep Fat Fryer	17
Dual-Pan Deep Fat Fryer with electronic control Plus	17
Dual-Pan Deep Fat Fryer with electronic control Plus and filter system	18
Dual-Pan Deep Fat Fryer with electronic control Plus, filter system and oil pump	19
Dual-Pan Deep Fat Fryer with electronic control Plus, filter system and basket lift	20
Dual-Pan Deep Fat Fryer with electronic control Plus, filter system, pump and basket lift	21
Chip Scuttle GN 1/1	22
Bain Marie GN 1/1	23
Bain Marie GN 2/1	24
Vario Cooker GN 1/1	25
Vario Cooker GN 1/1 with top-mounted electric heater	26
Pasta Cooker GN 1/1	26
Pasta Cooker GN 1/1 with 2 automatic lifting baskets	27
Pasta Cooker GN 1/1 with 4 automatic lifting baskets	27
Vario Pan 400	28
Vario Pan 600	28
Vario Pan 800 CC	29
Vario Pan 800 SC	29
Vario Grill Pan	30
Vario Pan M	30
Vario Pan Plus GN 2/1 U	31
Griddle plate 400	32
Griddle Plate 600	32

PALUX Topline Thermal - List of Contents

	Page
Kettle	33
Ceramic Range 1	34
Ceramic Range 2	34
Vario Range 1 (CNS)	35
Vario Range 1 (CNS)-Version for baking oven GN 1 1/2	35
Vario Range 2 (CNS)	35
Vario Range 2 (CNS)-Version for baking oven GN 1 1/2	35
Steak Grill 400 with drain on front side	36
Steak grill 400 with drain downwards	36
Steak Grill 600 with drain on front side	37
Steak Grill 600 with drain downwards	37
Steak Grill 800 with drain on front side	38
Steak Grill 800 with drain downwards	38
Induction Pan	39
Induction Wok	39
Induction Range 1	40
Induction Range 2	40
Induction Range 3	40
Induction Range 4	41
Induction Range 4F	41
Induction Range 5	41
Electric Baking Oven GN 1 1/2	42
Vario Gas Pan	42
Vario Gas Grill Pan	43
Gas Grill 600	44
Gas Grill 800	44
Gas Lava Stone Grill 600	45
Gas Lava Stone Grill 800	45
Gas Hot Plate	46
2-Burner Gas Range	47
4-Burner Gas Range	47

PALUX Topline Thermal - List of Contents

	Page
Accessories Gas Hot Plate	47
Work tops	48
Topline Black Edition in colour variation	49
Accessories Deep Fat Fryer	49
Optimal Equipment Oil/Fat-Filter-Pump System	49
Accessories Chip Scuttle	49
Accessories Vario Cooker	50
Accessories Pasta Cooker	50
Accessories Vario Range	50
Accessories Steak Grill	50
Accessories Induction Wok	50
Accessories Vario Pan / Griddle Plate	51
Accessories Kettle	51
Accessories Baking Oven	51
Lateral side part	52
Lateral side panel	53
Installation versions for Topline Base Cabinets	54
Feet for Standard Base Cabinet TLG	54
Castors for Standard Base Cabinet TLG	54
Feet for Base Cabinet Hygiene & Refrigeration	54
Plinth panel / plinth frame	55
Optional feature - Mobile Base Cabinet	55
Connecting plug	55
Appliance Connection	55
Side panel	55
Adapter Board	56
Handrail	56
Board on Column	57
Support for a Mixer	58
Splash guard	59
Partition wall	59

PALUX Topline Thermal - List of Contents

	Page
Accessories Line Assembly	60
Accessories Block Assembly	61
Product Code Base cabinet TLG & UG	62
Base cabinet closed on three sides TLGOS	63
Base cabinet with folding door(s) TLGFT	63
Base cabinet with drawer(s) TLGSB	64
Base cabinet with garbage drawer TLGMA	64
Base cabinet as installation cabinet with folding door TLGIF	65
Base cabinet with front panel TLGIB	65
Base cabinet with GN slides TLGGN	66
Base cabinet closed on three sides for Vario Pan TLGVB	66
Base cabinet as heated cabinet with sliding doors TLGWT	67
Base cabinet as heated cabinet with folding doors TLGWF	67
Base cabinet refrigerated element 2xGN 1/1 with refrigeration machine UGKE-M	68
Base cabinet refrigerated element 2 x GN 1/1 with installation cabinet UGKE-I	69
Product Code Base cabinet Hygiene UH	70
Base cabinet Hygiene closed on three sides UHOS	71
Base cabinet Hygiene with folding door(s) UHFT	71
Base cabinet Hygiene with drawer(s) UHSB	72
Base cabinet Hygiene with GN slides UHGN	72
Base cabinet Hygiene with garbage container UHMA	73
Base cabinet Hygiene for Vario Pan UHVB	73
PALUX Topline Thermal Stated Dimensions	74
PALUX Topline Thermal Heat Emission	76

All indicated prices are net prices and are valid for a delivery within 6 weeks after placement of the order. If delivery has to be made later than 6 weeks after placement of the order, the prices will be adjusted according to the then valid price-list. All prices are per item. Our terms of delivery are: EXW Bad Mergentheim (according to Incoterms 2010), packing for land transport included, excluding vat. The prices mentioned in this price-list do not include installation of the appliances.

**All listed values are middle values and refer to normal operation.
Calculated in accordance with VDI 2052 04/2006.**

Subject to changes in power, dimensions and construction.

PALUX Topline Thermik

The design and functionality of the components correspond to the latest findings in terms of ergonomics, hygiene and technology.



- modern design in stainless steel with black operating foil.
- Can be set up as a single unit, wall unit or cooking block in depths of 800 - 1800 mm.
- Individual thermal units can be combined with own substructure program, most flexible, modern operating design.
- Most flexible design due to patented connection system with excellent hygiene standard.
- Ideal for classic and high performance businesses in the gastronomy, hotel and catering industry and communal catering.

Design options

In addition to the standard version, the following version is optionally available

- **Black Edition** - black operating foil with additional painting of the front panel in RAL 9011 (painted graphite black matt).

NEW in our program - digital display with electronic thermostat.

Many **units** are available **optionally** with digital display. Depending on the unit, either the temperature can be set to the degree or the power level can be set precisely in percent.



- Precise, degree accurate setting and display of the set temperature or power level.
- Fast response of the heating elements to temperature changes.
- State-of-the-art technology in trend-setting design!

Single-Pan Deep Fat Fryer		Art. No.	Price EUR
Swivelling heating element in the pan		649554	
Dimensions (LxDxH):	400 x 800 x 320 / 355 mm	Direct heat emission:	0,72 kW
Connected load:	8,0 kW 400 V 3N	Latent heat emission:	5,60 kW
		Steam emission:	8,24 kg / h

Pan dimension: 220 x 340 x 190 mm
 Pan capacity: 8.5 Litres - 11 Litres max.
 Range of temperature: 103-180 °C

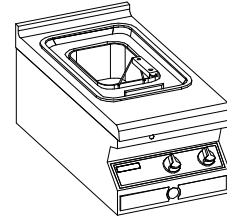

Accessories included: 1 x Appliance connection (696439)
 1 x Deep fat frying basket (271586)
 1 x Cover
 1 x Bread crumbs sieve
 1 x Handle for swivel fixture
 1 x Safety drainage valve

☞ When choosing the version with adapter board for thermal components and work tops, additional handles for swivel fixture have to be ordered/ Cf. accessories.

☞ **Optional equipment fat-filter-pump system / Cf. accessories.**

Single-Pan Deep Fat Fryer with electronic control Plus		Art. No.	Price EUR
Swivelling heating element in the pan		879987	
Dimensions (LxDxH):	400 x 800 x 320 / 355 mm	Direct heat emission:	0,72 kW
Connected load:	8,0 kW 400 V 3 50/60 Hz	Latent heat emission:	5,60 kW
		Steam emission:	8,24 kg / h

Pan dimension: 220 x 340 x 190 mm
 Pan capacity: 8.5 Litres - 11 Litres max.
 Range of temperature: 50 - 190 °C

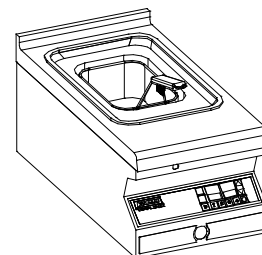

Accessories included: 1 x Appliance connection (696439)
 1 x Deep fat frying basket (271586)
 1 x Cover
 1 x Bread crumbs sieve
 1 x Handle for swivel fixture
 1 x Safety drainage valve

☞ When choosing the version with adapter board for thermal components and work tops, additional handles for swivel fixture have to be ordered/ Cf. accessories.

Single-Pan Deep Fat Fryer with electronic control Plus and filter system		Art. No.	Price EUR
Swivelling heating element in the pan		880006	
Dimensions (LxDxH):	400 x 800 x 750 / 900 mm	Direct heat emission:	0,72 kW
Connected load:	8,0 kW 400 V 3 50/60 Hz	Latent heat emission:	5,60 kW
		Steam emission:	8,24 kg / h

Pan dimension: 220 x 340 x 190 mm
 Pan capacity: 8.5 Litres - 11 Litres max.
 Range of temperature: 50 - 190°C
 Base cabinet closed on all sides with folding door (door hinging right)

Accessories included:

- 1 x Appliance connection (696439)
- 1 x Deep fat frying basket (271586)
- 1 x Cover
- 1 x Bread crumbs sieve
- 1 x Handle for swivel fixture
- 1 x Oil container
- 1 x Coarse and fine filter

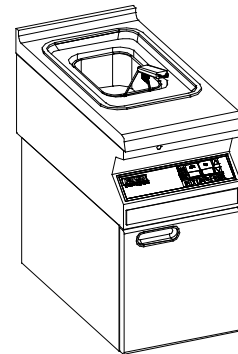

☞ When choosing the version with adapter board for thermal components and work tops, additional handles for swivel fixture have to be ordered/ Cf. accessories.

Single-Pan Deep Fat Fryer with electronic control Plus and filter system		Art. No.	Price EUR
Swivelling heating element in the pan		880152	
Dimensions (LxDxH):	400 x 800 x 750 / 900 mm	Direct heat emission:	0,72 kW
Connected load:	8,0 kW 400 V 3 50/60 Hz	Latent heat emission:	5,60 kW
		Steam emission:	8,24 kg / h

Base cabinet closed on all sides with folding door (door hinging left)
 Compare Art. No. 880006

☞ When choosing the version with adapter board for thermal components and work tops, additional handles for swivel fixture have to be ordered/ Cf. accessories.

Single-Pan Deep Fat Fryer with electronic control Plus, filter system and oil pump		Art. No.	Price EUR
Swivelling heating element in the pan		884861	
Dimensions (LxDxH):	400 x 800 x 750 / 900 mm	Direct heat emission:	0,72 kW
Connected load:	8,0 kW 400 V 3 50/60 Hz	Latent heat emission:	5,60 kW
		Steam emission:	8,24 kg / h

Pan dimension: 220 x 340 x 190 mm
 Pan capacity: 8.5 Litres - 11 Litres max.
 Range of temperature: 50 - 190°C
 Base cabinet closed on all sides with folding door (door hinging right)

Accessories included:

- 1 x Appliance connection (696439)
- 1 x Deep fat frying basket (271586)
- 1 x Cover
- 1 x Bread crumbs sieve
- 1 x Handle for swivel fixture
- 1 x Oil container
- 1 x Coarse and fine filter
- 1x Supply tap and hose

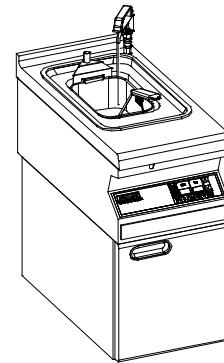

☞ When choosing the version with adapter board for thermal components and work tops, additional handles for swivel fixture have to be ordered/ Cf. accessories.

Single-Pan Deep Fat Fryer with electronic control Plus, filter system and oil pump		Art. No.	Price EUR
Swivelling heating element in the pan		884862	
Dimensions (LxDxH):	400 x 800 x 750 / 900 mm	Direct heat emission:	0,72 kW
Connected load:	8,0 kW 400 V 3 50/60 Hz	Latent heat emission:	5,60 kW
		Steam emission:	8,24 kg / h

Base cabinet closed on all sides with folding door (door hinging left)
 Compare Art. No. 884861

☞ When choosing the version with adapter board for thermal components and work tops, additional handles for swivel fixture have to be ordered/ Cf. accessories.

Single-Pan Deep Fat Fryer with electronic control Plus, filter system and basket lift		Art. No.	Price EUR
Swivelling heating element in the pan		880007	
Dimensions (LxDxH):	400 x 800 x 750 / 900 mm	Direct heat emission:	0,72 kW
Connected load:	8,0 kW 400 V 3 50/60 Hz	Latent heat emission:	5,60 kW
		Steam emission:	8,24 kg / h

Pan dimension: 220 x 340 x 190 mm
 Pan capacity: 8.5 Litres - 11 Litres max.
 Range of temperature: 50 - 190°C
 Base cabinet closed on all sides with folding door (door hinging right)

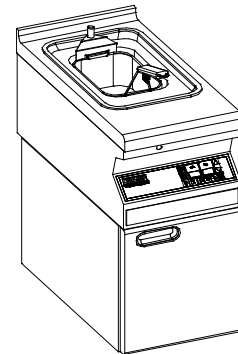

Accessories included:

- 1 x Appliance connection (696439)
- 1 x Deep fat frying basket (271586)
- 1x Basket holder
- 1 x Cover
- 1 x Bread crumbs sieve
- 1 x Handle for swivel fixture
- 1 x Oil container
- 1 x Coarse and fine filter

☞ When choosing the version with adapter board for thermal components and work tops, additional handles for swivel fixture have to be ordered/ Cf. accessories.

Single-Pan Deep Fat Fryer with electronic control Plus, filter system and basket lift		Art. No.	Price EUR
Swivelling heating element in the pan		880153	
Dimensions (LxDxH):	400 x 800 x 750 / 900 mm	Direct heat emission:	0,72 kW
Connected load:	8,0 kW 400 V 3 50/60 Hz	Latent heat emission:	5,60 kW
		Steam emission:	8,24 kg / h

Base cabinet closed on all sides with folding door (door hinging left)
 Compare Art. No. 880007

☞ When choosing the version with adapter board for thermal components and work tops, additional handles for swivel fixture have to be ordered/ Cf. accessories.

Single-Pan Deep Fat Fryer with electronic control Plus, filter system, pump and basket lift		Art. No.	Price EUR
Swivelling heating element in the pan		880008	
Dimensions (LxDxH):	400 x 800 x 750 / 900 mm	Direct heat emission:	0,72 kW
Connected load:	8,0 kW 400 V 3 50/60 Hz	Latent heat emission:	5,60 kW
		Steam emission:	8,24 kg / h

Pan dimension: 220 x 340 x 190 mm
 Pan capacity: 8.5 Litres - 11 Litres max.
 Range of temperature: 50 - 190°C
 Base cabinet closed on all sides with folding door (door hinging right)

Accessories included:

- 1 x Appliance connection (696439)
- 1 x Deep fat frying basket (271586)
- 1x Basket holder
- 1 x Cover
- 1 x Bread crumbs sieve
- 1 x Handle for swivel fixture
- 1 x Oil container
- 1 x Coarse and fine filter
- 1x Supply tap and hose

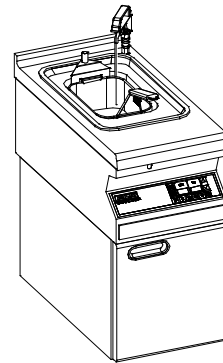

☞ When choosing the version with adapter board for thermal components and work tops, additional handles for swivel fixture have to be ordered/ Cf. accessories.

Single-Pan Deep Fat Fryer with electronic control Plus, filter system, pump and basket lift		Art. No.	Price EUR
Swivelling heating element in the pan		880154	
Dimensions (LxDxH):	400 x 800 x 750 / 900 mm	Direct heat emission:	0,72 kW
Connected load:	8,0 kW 400 V 3 50/60 Hz	Latent heat emission:	5,60 kW
		Steam emission:	8,24 kg / h

Base cabinet closed on all sides with folding door (door hinging left)
 Compare Art. No. 880008

☞ When choosing the version with adapter board for thermal components and work tops, additional handles for swivel fixture have to be ordered/ Cf. accessories.

Dual-Pan Deep Fat Fryer		Art. No.	Price EUR
Swivelling heating elements in the pans		649562	
Dimensions (LxDxH):	600 x 800 x 320 / 355 mm	Direct heat emission:	1,44 kW
Connected load:	2 x 8,0 (16,0) kW 400 V 3N	Latent heat emission:	11,20 kW
		Steam emission:	16,48 kg / h

- Pan dimension: 220 x 340 x 190 mm each
- Pan capacity: 8.5 Litres- 11 Litres max.
- Range of temperature: 103 - 180° C

- Accessories included:
 - 1 x Appliance connection (696439)
 - 2 x Deep fat frying basket (271586)
 - 2 x Cover
 - 2 x Bread crumbs sieve
 - 2 x Handle for swivel fixture
 - 2 x Safety drainage valve

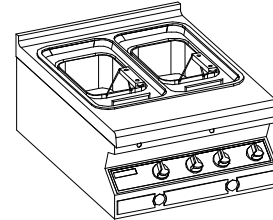

☞ When choosing the version with adapter board for thermal components and work tops, additional handles for swivel fixture have to be ordered/ Cf. accessories.

☞ **Optional equipment fat-filter-pump system / Cf. accessories.**

Dual-Pan Deep Fat Fryer with electronic control Plus		Art. No.	Price EUR
Swivelling heating elements in the pans		879965	
Dimensions (LxDxH):	600 x 800 x 320 / 355 mm	Direct heat emission:	1,44 kW
Connected load:	2 x 8,0 (16,0) kW 400 V 3 50/60 Hz	Latent heat emission:	11,20 kW
		Steam emission:	16,48 kg / h

- Pan dimension: 220 x 340 x 190 mm each
- Pan capacity: 8.5 Litres - 11 Litres max.
- Range of temperature: 50 - 190° C
- Accessories included:
 - 1 x Appliance connection (696439)
 - 2 x Deep fat frying basket (271586)
 - 2 x Cover
 - 2 x Bread crumbs sieve
 - 2 x Handle for swivel fixture
 - 2 x Safety drainage valve

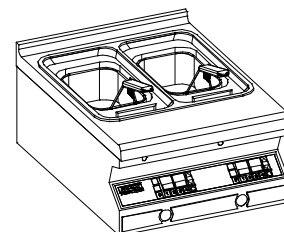

☞ When choosing the version with adapter board for thermal components and work tops, additional handles for swivel fixture have to be ordered/ Cf. accessories.

Dual-Pan Deep Fat Fryer with electronic control Plus and filter system		Art. No.	Price EUR
Swivelling heating elements in the pans		880009	
Dimensions (LxDxH):	600 x 800 x 750 / 900 mm	Direct heat emission:	1,44 kW
Connected load:	2 x 8,0 (16,0) kW 400 V 3 50/60 Hz	Latent heat emission:	11,20 kW
		Steam emission:	16,48 kg / h

Pan dimension: 220 x 340 x 190 mm each
 Pan capacity: 8.5 Litres - 11 Litres max.
 Range of temperature: 50 - 190°C
 Base cabinet closed on all sides with folding door (door hinging right)

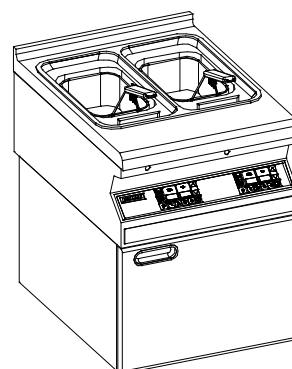

Accessories included:

- 1 x Appliance connection (696439)
- 2 x Deep fat frying basket (271586)
- 2 x Cover
- 2 x Bread crumbs sieve
- 2 x Handle for swivel fixture
- 1 x Oil container
- 2 x Coarse and fine filter

☞ When choosing the version with adapter board for thermal components and work tops, additional handles for swivel fixture have to be ordered/ Cf. accessories.

Dual-Pan Deep Fat Fryer with electronic control Plus and filter system		Art. No.	Price EUR
Swivelling heating elements in the pans		880158	
Dimensions (LxDxH):	600 x 800 x 750 / 900 mm	Direct heat emission:	1,44 kW
Connected load:	2 x 8,0 (16,0) kW 400 V 3 50/60 Hz	Latent heat emission:	11,20 kW
		Steam emission:	16,48 kg / h

Base cabinet closed on all sides with folding door (door hinging left)
 Compare Art. No. 880009

☞ When choosing the version with adapter board for thermal components and work tops, additional handles for swivel fixture have to be ordered/ Cf. accessories.

Dual-Pan Deep Fat Fryer with electronic control Plus, filter system and oil pump		Art. No.	Price EUR
Swivelling heating elements in the pans		884851	
Dimensions (LxDxH):	600 x 800 x 750 / 900 mm	Direct heat emission:	1,44 kW
Connected load:	2 x 8,0 (16,0) kW 400 V 3 50/60 Hz	Latent heat emission:	11,20 kW
		Steam emission:	16,48 kg / h

Pan dimension: 220 x 340 x 190 mm each
 Pan capacity: 8.5 Litres - 11 Litres max.
 Range of temperature: 50 - 190°C
 Base cabinet closed on all sides with folding door (door hinging right)

Accessories included:

- 1 x Appliance connection (696439)
- 2 x Deep fat frying basket (271586)
- 2 x Cover
- 2 x Bread crumbs sieve
- 2 x Handle for swivel fixture
- 1 x Oil container
- 2 x Coarse and fine filter
- 1x Supply tab and hose

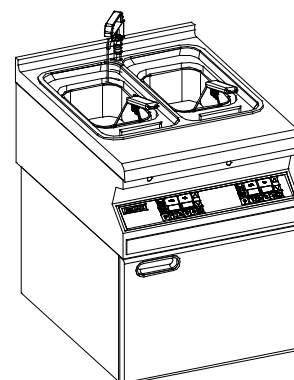

☞ When choosing the version with adapter board for thermal components and work tops, additional handles for swivel fixture have to be ordered/ Cf. accessories.

Dual-Pan Deep Fat Fryer with electronic control Plus, filter system and oil pump		Art. No.	Price EUR
Swivelling heating elements in the pans		884852	
Dimensions (LxDxH):	600 x 800 x 750 / 900 mm	Direct heat emission:	1,44 kW
Connected load:	2 x 8,0 (16,0) kW 400 V 3 50/60 Hz	Latent heat emission:	11,20 kW
		Steam emission:	16,48 kg / h

Base cabinet closed on all sides with folding door (door hinging left)
 Compare Art. No. 884851

☞ When choosing the version with adapter board for thermal components and work tops, additional handles for swivel fixture have to be ordered/ Cf. accessories.

Dual-Pan Deep Fat Fryer with electronic control Plus, filter system and basket lift		Art. No.	Price EUR
Swivelling heating elements in the pans		880010	
Dimensions (LxDxH):	600 x 800 x 750 / 900 mm	Direct heat emission:	1,44 kW
Connected load:	2 x 8,0 (16,0) kW 400 V 3 50/60 Hz	Latent heat emission:	11,20 kW
		Steam emission:	16,48 kg / h

Pan dimension: 220 x 340 x 190 mm each
 Pan capacity: 8.5 Litres - 11 Litres max.
 Range of temperature: 50 - 190°C
 Base cabinet closed on all sides with folding door (door hinging right)

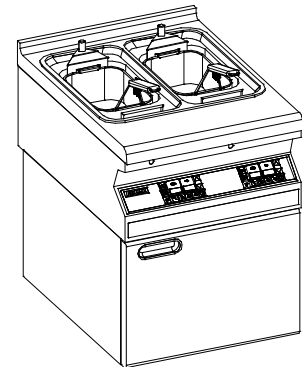

Accessories included:

- 1 x Appliance connection (696439)
- 2 x Deep fat frying basket (271586)
- 2 x Basket holder
- 2 x Cover
- 2 x Bread crumbs sieve
- 2 x Handle for swivel fixture
- 1 x Oil container
- 2 x Coarse and fine filter

☞ When choosing the version with adapter board for thermal components and work tops, additional handles for swivel fixture have to be ordered/ Cf. accessories.

Dual-Pan Deep Fat Fryer with electronic control Plus, filter system and basket lift		Art. No.	Price EUR
Swivelling heating elements in the pans		880160	
Dimensions (LxDxH):	600 x 800 x 750 / 900 mm	Direct heat emission:	1,44 kW
Connected load:	2 x 8,0 (16,0) kW 400 V 3 50/60 Hz	Latent heat emission:	11,20 kW
		Steam emission:	16,48 kg / h

Base cabinet closed on all sides with folding door (door hinging left)
 Compare Art. No. 880010

☞ When choosing the version with adapter board for thermal components and work tops, additional handles for swivel fixture have to be ordered/ Cf. accessories.

Dual-Pan Deep Fat Fryer with electronic control Plus, filter system, pump and basket lift		Art. No.	Price EUR
Swivelling heating elements in the pans		880011	
Dimensions (LxDxH):	600 x 800 x 750 / 900 mm	Direct heat emission:	1,44 kW
Connected load:	2 x 8,0 (16,0) kW 400 V 3 50/60 Hz	Latent heat emission:	11,20 kW
		Steam emission:	16,48 kg / h

Pan dimension: 220 x 340 x 190 mm each
 Pan capacity: 8.5 Litres - 11 Litres max.
 Range of temperature: 50 - 190°C
 Base cabinet closed on all sides with folding door (door hinging right)

Accessories included:

- 1 x Appliance connection (696439)
- 2 x Deep fat frying basket (271586)
- 2 x Basket holder
- 2 x Cover
- 2 x Bread crumbs sieve
- 2 x Handle for swivel fixture
- 1 x Oil container
- 2 x Coarse and fine filter
- 1x Supply tab and hose

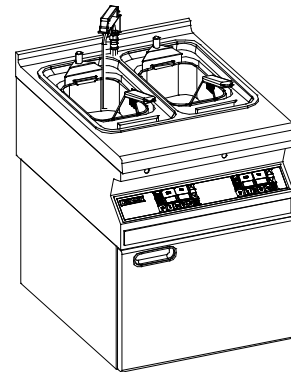

☞ When choosing the version with adapter board for thermal components and work tops, additional handles for swivel fixture have to be ordered/ Cf. accessories.

Dual-Pan Deep Fat Fryer with electronic control Plus, filter system, pump and basket lift		Art. No.	Price EUR
Swivelling heating elements in the pans		880161	
Dimensions (LxDxH):	600 x 800 x 750 / 900 mm	Direct heat emission:	1,44 kW
Connected load:	2 x 8,0 (16,0) kW 400 V 3 50/60 Hz	Latent heat emission:	11,20 kW
		Steam emission:	16,48 kg / h

Base cabinet closed on all sides with folding door (door hinging left)
 Compare Art. No. 880011

☞ When choosing the version with adapter board for thermal components and work tops, additional handles for swivel fixture have to be ordered/ Cf. accessories.

Chip Scuttle GN 1/1		Art. No.	Price EUR
Swivelling heating with top-mounted electric heater		659002	
	Topline D	889585	
Dimensions (LxDxH):	400 x 800 x 320 / 355 mm	Direct heat emission:	0,08 kW
Connected load:	0,6 kW 230 V 1 N	Latent heat emission:	0,12 kW

Pan dimension: 308 x 509 x 215 mm
 Accessories included: 1 x Appliance connection (696439)

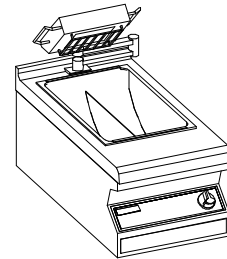

Illustrated containers are not included in the price of all types of devices.

Bain Marie GN 1/1		Art. No.	Price EUR
Heated indirectly		667412	
	Topline D	889528	
Dimensions (LxDxH):	400 x 800 x 320 / 355 mm	Direct heat emission:	0,25 kW
Connected load:	2,0 kW 230 V 1N	Latent heat emission:	0,40 kW
		Steam emission:	0,59 kg / h

Pan dimension: 308 x 509 x 215 mm

Accessories included: 1 x Appliance connection (696439)
1 x Safety drainage valve

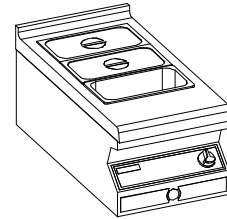

Bain Marie GN 1/1 with drain to the rear		Art. No.	Price EUR
Heated indirectly		140902	
	Topline D	889529	

Compare Art. No. 667412

☞ Use base cabinets of the TLGOS/UHOS or TLGFT/UHFT-type !

Bain Marie GN 1/1 with water supply		Art. No.	Price EUR
Heated indirectly		879896	
	Topline D	889530	

Compare Art. No. 667412

Bain Marie GN 1/1 with water supply and drain to the rear		Art. No.	Price EUR
Heated indirectly		879897	
	Topline D	889531	

Compare Art. No. 667412

☞ Use base cabinets of the TLGOS/UHOS or TLGFT/UHFT-type !

☞ **Illustrated containers are not included in the price of all types of devices!**

Bain Marie GN 2/1		Art. No.	Price EUR
Heated indirectly		684848	
	Topline D	889532	
Dimensions (LxDxH):	800 x 800 x 320 / 355 mm	Direct heat emission:	0,50 kW
Connected load:	4,0 kW 400 V 3N	Latent heat emission:	0,80 kW
		Steam emission:	1,18 kg / h

Pan dimension: 630 x 510 x 215 mm

Accessories included: 1 x Appliance connection (696439)
 1 x Safety drainage valve
 1 x Bridge, Length 530 mm (371378)

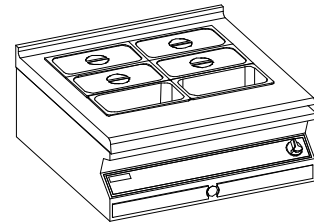

Bain Marie GN 2/1 with drain to the rear		Art. No.	Price EUR
Heated indirectly		832995	
	Topline D	889533	

Compare Art. No. 684848

☞ Use base cabinets of the TLGOS/UHOS or TLGFT/UHFT-type !

Bain Marie GN 2/1 with water supply		Art. No.	Price EUR
Heated indirectly		879898	
	Topline D	889534	

Compare Art. No. 684848

Bain Marie GN 2/1 with water supply and drain to the rear		Art. No.	Price EUR
Heated indirectly		879899	
	Topline D	889535	

Compare Art. No. 684848

☞ Use base cabinets of the TLGOS/UHOS or TLGFT/UHFT-type !

☞ **Illustrated containers are not included in the price of all types of devices!**

Vario Cooker GN 1/1 with swivelling flat tube heating elements		Art. No.	Price EUR
		503010	
	Topline D	889565	
Dimensions (LxDxH):	400 x 800 x 320 / 355 mm	Direct heat emission:	0,86 kW
Connected load:	7,0 kW 400 V 3N	Latent heat emission:	1,40 kW
		Steam emission:	2,06 kg / h

Pan dimension: 308 x 509 x 240 mm
Pan capacity: 35 Litres

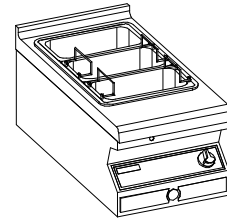

Accessories included: 1 x Appliance connection (696439)
1 x Handle for swivel fixture
1 x Safety drainage valve

☞ When choosing the version with adapter board for thermal components and work tops, additional handles for swivel fixture have to be ordered/ Cf. Accessories.

Vario Cooker GN 1/1 with drain to the rear with swivelling flat tube heating elements		Art. No.	Price EUR
		517887	
	Topline D	889566	

Compare Art. No. 503010

☞ Use base cabinets of the TLGOS/UHOS or TLGFT/UHFT-type !

Vario Cooker GN 1/1 with water supply with swivelling flat tube heating elements		Art. No.	Price EUR
		730610	
	Topline D	889567	

Compare Art. No. 503010

Vario Cooker GN 1/1 with water supply and drain to the rear with swivelling flat tube heating elements		Art. No.	Price EUR
		730629	
	Topline D	889568	

Compare Art. No. 503010

☞ Use base cabinets of the TLGOS/UHOS or TLGFT/UHFT-type !

☞ **Illustrated containers are not included in the price of all types of devices!**

Vario Cooker GN 1/1 with top-mounted electric heater		Art. No.	Price EUR
with swivelling flat tube heating elements		657735	
	Topline D	889569	
Dimensions (LxDxH):	400 x 800 x 320 / 355 mm	Direct heat emission:	0,95 kW
Connected load:	7,6 kW 400 V 3N	Latent heat emission:	1,52 kW
		Steam emission:	2,23 kg / h

Pan dimension: 308 x 509 x 240 mm
 Pan capacity: 35 Litres

Accessories included: 1 x Appliance connection (696439)
 1 x Handle for swivel fixture
 1 x Safety drainage valve

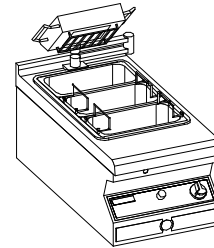

☞ When choosing the version with adapter board for thermal components and work tops, additional handles for swivel fixture have to be ordered/ Cf. Accessories.

Pasta Cooker GN 1/1		Art. No.	Price EUR
Water supply and water drain downwards		949590	
	Topline D	889599	
Dimensions (LxDxH):	400 x 800 x 750 / 900 mm	Direct heat emission:	0,86 kW
Connected load:	7,0 kW 400 V 3N	Latent heat emission:	1,40 kW
		Steam emission:	2,06 kg / h

Pan dimension: 308 x 509 x 240 mm
 Pan capacity: 35 Litres
 Base cabinet in hygienic version H2

Accessories included: 1 x Appliance connection (696439)
 1x Perforated insert (951285)
 1x stainless steel starch separator (889380)
 1x Drip plate (951250)
 1x Grid (951439)

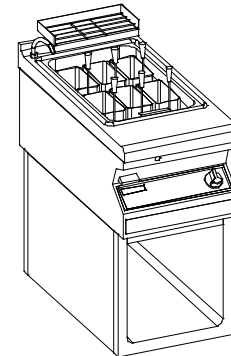

Pasta Cooker GN 1/1		Art. No.	Price EUR
Water supply and water drainage none detachable on rear		949604	
	Topline D	889600	
Dimensions (LxDxH):	400 x 800 x 750 / 900 mm	Direct heat emission:	0,86 kW
Connected load:	7,0 kW 400 V 3N	Latent heat emission:	1,40 kW
		Steam emission:	2,06 kg / h

Compare Art. No. 949 590

☞ **Illustrated containers are not included in the price of all types of devices!**

Pasta Cooker GN 1/1 with 2 automatic lifting baskets		Art. No.	Price EUR
Water supply and water drainage none detachable on rear		953504	
	Topline D	889601	
Dimensions (LxDxH):	600 x 800 x 750 / 1120 mm	Direct heat emission:	0,86 kW
Connected load:	7,0 kW 400 V 3N	Latent heat emission:	1,40 kW
		Steam emission:	2,06 kg / h

Pan dimension: 308 x 509 x 240 mm
 Pan capacity: 35 Litres
 Operation with electrical control and digital display, start/stop button
 With 2 lifting devices right
 With standard base cabinet: 600 x 710 x 430 mm

Accessories included: 1x Appliance connection (696439)
 1x Perforated insert (951285)
 1x stainless steel starch separator (889380)
 4x Pasta basket (955965) 130 x 185 x 200 mm

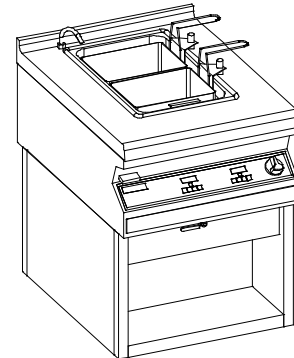

Pasta Cooker GN 1/1 with 4 automatic lifting baskets		Art. No.	Price EUR
Water supply and water drainage none detachable on rear		953512	
	Topline D	889602	
Dimensions (LxDxH):	600 x 800 x 750 / 1120 mm	Direct heat emission:	0,86 kW
Connected load:	7,0 kW 400 V 3N	Latent heat emission:	1,40 kW
		Steam emission:	2,06 kg / h

Pan dimension: 308 x 509 x 240 mm
 Pan capacity: 35 Litres
 Operation with electrical control and digital display, start/stop button
 With 2 lifting devices right/ 2 lifting devices left
 With standard base cabinet: 600 x 710 x 430 mm

Accessories included: 1x Appliance connection (696439)
 1x Perforated insert (951285)
 1x stainless steel starch separator (889380)
 4x Pasta basket (955965) 130 x 185 x 200 mm

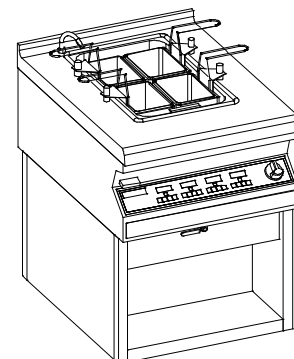

Vario Pan 400		Art. No.	Price EUR
High-gloss polished stainless steel roasting grilling top / special composition of top with vacuum-soldered copper plate		502650	
	Topline D	889277	
Dimensions (LxDxH):	400 x 800 x 320 / 355 mm	Direct heat emission:	1,27 kW
Connected load:	4,8 kW 400 V 3N	Latent heat emission:	1,54 kW
		Steam emission:	2,26 kg / h

Pan dimension: 330 x 569 x 75 mm
 Pan capacity: 13 Litres
 Cooking surface: 330 x 470 mm
 Heating zone: 1x 4,8 kW
 Range of temperature: 95 - 250°C

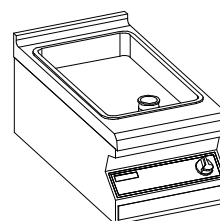

Accessories included:

- 1 x Appliance connection (696439)
- 1 x GN 1/1 - Container 200 mm deep with curved handles (607207)
- 1 x Perforated lid (615196)
- 1 x Drain plug (502073)
- 1 x Cleaning scraper (614319)

☞ Use base cabinets of the TLGVB or UHVB-type !

Vario Pan 600		Art. No.	Price EUR
High-gloss polished stainless steel roasting grilling top / special composition of top with vacuum-soldered copper plate		502707	
	Topline D	889279	
Dimensions (LxDxH):	600 x 800 x 320 / 355 mm	Direct heat emission:	1,85 kW
Connected load:	7,0 kW 400 V 3N	Latent heat emission:	2,24 kW
		Steam emission:	3,29 kg / h

Pan dimension: 530 x 569 x 75 mm
 Pan capacity: 21 Litres
 Cooking surface: 530 x 470 mm
 Heating zones: 2x 3.5 kW
 Range of temperature: 95 - 250°C

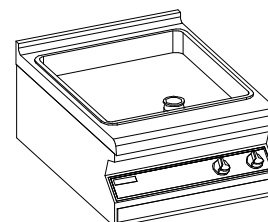

Accessories included:

- 1 x Appliance connection (696439)
- 1 x GN 1/1 - Container 200 mm deep, with curved handles (607207)
- 1 x Perforated lid (615196)
- 1 x Drain plug (502073)
- 1 x Cleaning scraper (614319)

☞ Use base cabinets of the TLGVB or UHVB-type !

Vario Pan 800 CC		Art. No.	Price EUR
High-gloss polished stainless steel roasting grilling top / special composition of top with vacuum-soldered copper core		879316	
	Topline D	889281	
Dimensions (LxDxH):	800 x 800 x 320 / 355 mm	Direct heat emission:	2,77 kW
Connected load:	10,5 kW 400 V 3N	Latent heat emission:	3,36 kW
		Steam emission:	4,93 kg / h

Pan dimension: 680 x 580 x 75 mm
 Pan capacity: 29 Litres
 Cooking surface: 680 x 480 mm
 Heating zones: 3x 3,5 kW
 Range of temperature: 95 - 250°C

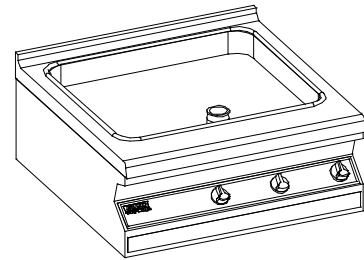

Accessories included:

- 1 x Appliance connection (696439)
- 1 x GN 1/1 - Container 200 mm deep, with curved handles (607207)
- 1 x Perforated lid (615196)
- 1 x Drain plug (502073)
- 1 x Cleaning scraper (614319)

☞ Use base cabinets of the TLGVB or UHVB-type !

Vario Pan 800 SC		Art. No.	Price EUR
High-gloss polished stainless steel roasting grilling top / special composition of top with vacuum-soldered steel core		880123	
	Topline D	889282	
Dimensions (LxDxH):	800 x 800 x 320 / 355 mm	Direct heat emission:	2,77 kW
Connected load:	10,5 kW 400 V 3N	Latent heat emission:	3,36 kW
		Steam emission:	4,93 kg / h

Pan dimension: 680 x 580 x 75 mm
 Pan capacity: 29 Litres
 Cooking surface: 680 x 480 mm
 Heating zones: 3x 3,5 kW
 Range of temperature: 95 - 250°C

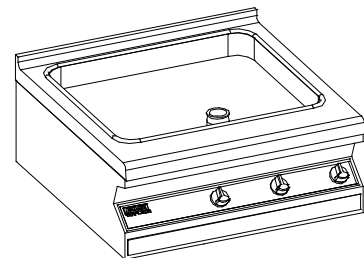

Accessories included:

- 1 x Appliance connection (696439)
- 1 x GN 1/1 - Container 200 mm deep, with curved handles (607207)
- 1 x Perforated lid (615196)
- 1 x Drain plug (502073)
- 1 x Cleaning scraper (614319)

☞ Use base cabinets of the TLGVB or UHVB-type !

Vario Grill Pan		Art. No.	Price EUR
Grooved steel plate with gradient		725315	
		Topline D 889283	
Dimensions (LxDxH):	600 x 800 x 320 / 355 mm	Direct heat emission:	3,30 kW
Connected load:	10,0 kW 400 V 3N	Latent heat emission:	4,00 kW
		Steam emission:	5,88 kg / h

Pan capacity: 21 Litres
 Grilling surface: 530 x 465 mm
 Heating zones: 2x 5.0 kW
 Range of temperature: 100 - 250°C

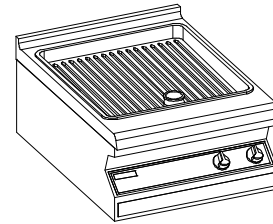

Accessories included:

- 1 x Appliance connection (696439)
- 1 x GN 1/1 - Container 200 mm deep with curved handles (607207)
- 1 x Perforated lid (615196)
- 1 x Drain plug (502073)
- 1 x Cleaning brush (614319)
- 1 x Cleaning scraper (727563)

☞ Use base cabinet of the TLGVB or UHVB-type !

Vario Pan M		Art. No.	Price EUR
with base cabinet in hygienic version H2		811084	
		Topline D 889284	
Dimensions (LxDxH):	600 x 800 x 750 / 820mm	Direct heat emission:	2,64 kW
Connected load:	10,0 kW 400 V 3N	Latent heat emission:	3,20 kW
		Steam emission:	4,70 kg / h

Pan dimension: 530 x 569 x 150 mm
 Pan capacity: 40 Litres
 Grilling surface: 530 x 470 mm
 Heating zones: 2x 5.0 kW
 Range of temperature: 95 - 250°C
 Incl. water supply and mixing tap

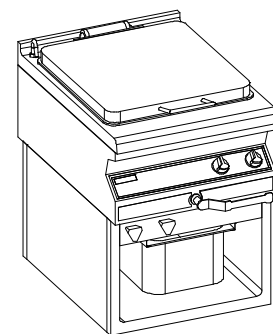

Accessories included:

- 1 x Appliance connection (696439)
- 1 x Drain plug, 170 mm high (337684)
- 1 x GN 1/1 - container 200 mm deep with curved handles (607207)
- 1 x Perforated lid (615196)
- 1 x Cleaning brush (614319)
- 1 x Sieve (346802)

Vario Pan Plus GN 2/1 U		Art. No.	Price EUR
Open base unit		144819	
Dimensions (LxDxH):	800 x 800 x 750 / 807 mm	Direct heat emission:	3,56 kW
Connected load:	13,5 kW 400 V 3N	Latent heat emission:	4,32 kW
		Steam emission:	6,35 kg / h

- Pan dimensions: 680 x 580 x 210 mm
- Pan capacity max.: 80 Litres
- Filling level max.: 60 Litres
- Integrated water supply
- Accessories included:
 - 1 x Appliance connection (696439)
 - 1 x GN 1/1 - Container 200 mm deep with curved handles (607207)
 - 1 x Perforated lid (615196)
 - 1 x Drain plug, 170 mm high (337684)
 - 1 x Cleaning brush (614319)
 - 1 x Sieve (866180)

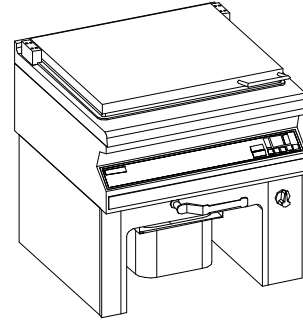

Drainage carriage CNS		Art. No.	Price EUR
for Vario Pan Plus		354554	
Dimensions (LxDxH):	367 x 570 x 425 mm		

For GN 1/1 containers
 4 castors Ø 125 mm, of which 2 can be locked

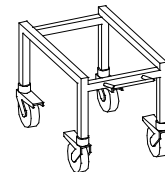

Griddle plate 400		Art. No.	Price EUR
Cooking surface made of special steel 1.2316		879641	
	Topline D	889286	
Dimensions (LxDxH):	400 x 800 x 320 / 355 mm	Direct heat emission:	1,58 kW
Connected load:	4,8 kW 400 V 3N	Latent heat emission:	2,68 kW
		Steam emission:	2,26 kg / h

Pan dimension: 330 x 569 x 40 mm
 Cooking surface: 330 x 470 mm
 Heating zone: 1x 4,8 kW
 Range of temperature: 95 - 250°C

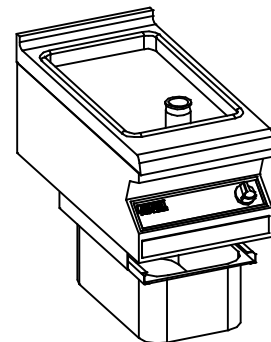

Accessories included: 1 x Appliance connection (696439)
 1 x GN 1/1 - Container 200 mm deep with curved handles (607207)
 1 x Perforated lid (615196)
 1 x Drain plug (502073)
 1 x Cleaning scraper (614319)

☞ Use base cabinets of the TLGVB or UHVB-type !

Griddle Plate 600		Art. No.	Price EUR
Cooking surface made of special steel 1.2316		879642	
	Topline D	889287	
Dimensions (LxDxH):	600 x 800 x 320 / 355 mm	Direct heat emission:	2,31 kW
Connected load:	7,0 kW 400 V 3N	Latent heat emission:	3,91 kW
		Steam emission:	4,11 kg / h

Pan dimension: 530 x 569 x 40 mm
 Cooking surface: 530 x 470 mm
 Heating zones: 2x 3.5 kW
 Range of temperature: 95 - 250°C

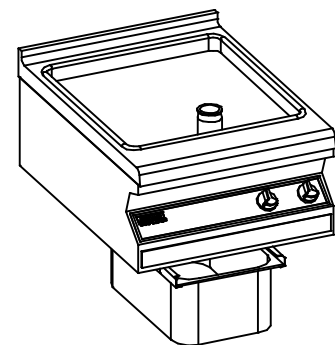

Accessories included: 1 x Appliance connection (696439)
 1 x GN 1/1 - Container 200 mm deep, with curved handles (607207)
 1 x Perforated lid (615196)
 1 x Drain plug (502073)
 1 x Cleaning scraper (614319)

☞ Use base cabinets of the TLGVB or UHVB-type !

Kettle		Art. No.	Price EUR
80 litres		880980	
Dimensions (LxDxH):	800 x 800 x 750 mm	Direct heat emission:	0,65 kW
Connected load:	18,6 kW 400 V 3N	Latent heat emission:	3,72 kW
		Steam emission:	5,47 kg / h

Nominal capacity: 80 Litres
 Effective capacity: 93 Litres (with 40 mm boiling edge)
 Internal boiler: Ø 584 mm / Height 410 mm
 Electronic temperature control
 Permapress heating system
 Water inlet with mixing valve in the front panel

Accessories included: 1 x Appliance connection (696439)

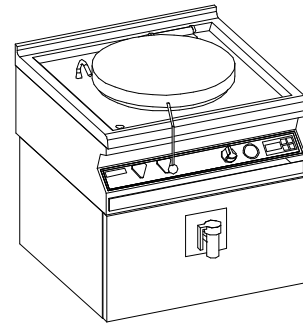

Ceramic Range 1		Art. No.	Price EUR
Flush, seamless glass ceramic cool top		733105	
	Topline D	889604	
Dimensions (LxDxH):	400 x 800 x 320 / 355 mm	Direct heat emission:	1,40 kW
Connected load:	7,0 kW 400 V 3N	Latent heat emission:	0,56 kW
		Steam emission:	0,83 kg / h

Ceramic hob: 394,5 x 688 mm
 Heating zones: 2x of 3.5 kW, each 270 x 270 mm
 With pot detection and manual change- over switch

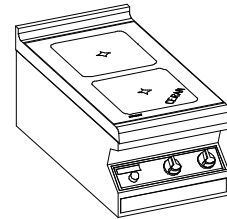

Accessories included: 1 x Appliance connection (696439)

Ceramic Range 2		Art. No.	Price EUR
Flush, seamless glass ceramic cool top		733113	
	Topline D	889605	
Dimensions (LxDxH):	800 x 800 x 320 / 355 mm	Direct heat emission:	2,80 kW
Connected load:	2 x 7,0 (14,0) kW 400 V 3N	Latent heat emission:	1,12 kW
		Steam emission:	1,65 kg / h

Ceramic hob: 794 x 688 mm
 Heating zones: 4x 3.5 kW, each 270 x 270 mm
 With pot detection and manual change over switch

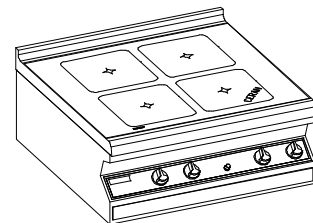

Accessories included: 1 x Appliance connection (696439)

Vario Range 1 (CNS)		Art. No.	Price EUR
Flush CNS cooking / frying top		687200	
	Topline D	889606	
Dimensions (LxDxH):	600 x 800 x 320 / 355 mm	Direct heat emission:	1,40 kW
Connected load:	7,0 kW 400 V 3N	Latent heat emission:	0,56 kW
		Steam emission:	0,83 kg / h

Cooking surface: 347 x 617 mm
 Heating zones: 2x 3.5 kW
 All-rounded collecting channel and fat collecting drawer

Accessories included: 1 x Appliance connection (696439)

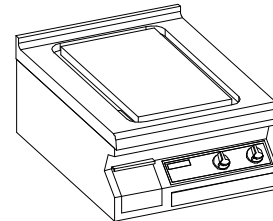

Vario Range 1 (CNS)-Version for baking oven GN 1 1/2		Art. No.	Price EUR
Flush CNS cooking / frying top		703095	
	Topline D	889608	

Compare Art. No. 687200

Vario Range 2 (CNS)		Art. No.	Price EUR
Flush CNS cooking / frying top		690600	
	Topline D	889609	
Dimensions (LxDxH):	800 x 800 x 320 / 355 mm	Direct heat emission:	2,80 kW
Connected load:	2 x 7,0 (14,0) kW 400 V 3N	Latent heat emission:	1,12 kW
		Steam emission:	1,65 kg / h

Cooking surface: 651 x 617 mm
 Heating zones: 4x 3.5 kW
 All-rounded collecting channel and fat collecting tray

Accessories included: 1 x Appliance connection (696439)

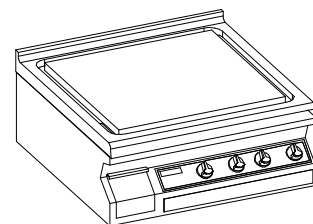

Vario Range 2 (CNS)-Version for baking oven GN 1 1/2		Art. No.	Price EUR
Flush CNS cooking / frying top		703109	
	Topline D	889611	

Compare Art. No. 690600

Steak Grill 400 with drain on front side		Art. No.	Price EUR
Grilling directly on CNS flat heating elements for typical grill pattern		883931	
	Topline D	889222	
Dimensions (LxDxH):	400 x 800 x 320 / 355 mm	Direct heat emission:	1,19 kW
Connected load:	3,6 kW 230 V 1N	Latent heat emission:	1,44 kW
		Steam emission:	2,12 kg / h

Grilling surface: 290 x 410 mm
 Heating zone: 1x 3,6 kW
 Grill temperature infinitely adjustable using energy controller
 CNS flat heating elements can be swivelled upwards for cleaning the pan
 Fat collecting pan with drain plug
 Drain on front side with safety valve

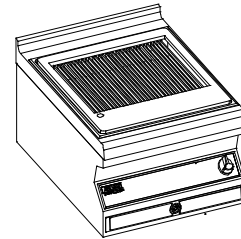

Accessories included: 1 x Appliance connection (696439)
 1 x Drain plug (869961)
 1 x Cleaning brush (864021)
 1 x Safety valve

Steak grill 400 with drain downwards		Art. No.	Price EUR
Grilling directly on CNS flat heating elements for typical grill pattern		883015	
	Topline D	889245	
Dimensions (LxDxH):	400 x 800 x 320 / 355 mm	Direct heat emission:	1,19 kW
Connected load:	3,6 kW 230 V 1N	Latent heat emission:	1,44 kW
		Steam emission:	2,12 kg / h

Grilling surface: 290 x 410 mm
 Heating zone: 1x 3,6 kW
 Grill temperature infinitely adjustable using energy controller
 CNS flat heating elements can be swivelled upwards for cleaning the pan
 Fat collecting pan with drain plug
 Drain downwards, 40 mm diameter

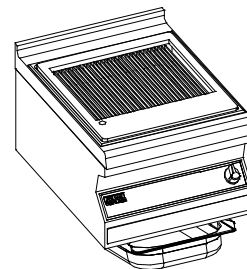

Accessories included: 1 x Appliance connection (696439)
 1 x Drain plug (869961)
 1 x Cleaning brush (864021)
 1 x GN 1/1 Container 100 mm deep, with curved handles (609773)
 1 x Perforated lid (615196)

☞ Use base cabinets of the TLGVB or UHVB-type !

Steak Grill 600 with drain on front side		Art. No.	Price EUR
Grilling directly on CNS flat heating elements for typical grill pattern		883932	
	Topline D	889248	
Dimensions (LxDxH):	600 x 800 x 320 / 355 mm	Direct heat emission:	1,68 kW
Connected load:	5,0 kW 400 V 3	Latent heat emission:	2,04 kW
		Steam emission:	3,00 kg / h

Grilling surface: 490 x 410 mm
 Heating zones: 2x 2,5 kW
 Grill temperature infinitely adjustable using energy controller
 CNS flat heating elements can be swivelled upwards for cleaning the pan
 Fat collecting pan with drain plug
 Drain on front side with safety valve

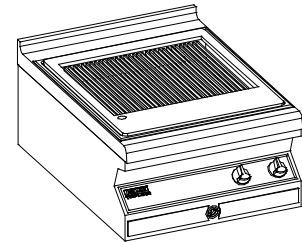

Accessories included:

- 1 x Appliance connection (696439)
- 1 x Drain plug (869961)
- 1 x Cleaning brush (864021)
- 1 x Safety valve

Steak Grill 600 with drain downwards		Art. No.	Price EUR
Grilling directly on CNS flat heating elements for typical grill pattern		883016	
	Topline D	889273	
Dimensions (LxDxH):	600 x 800 x 320 / 355 mm	Direct heat emission:	1,68 kW
Connected load:	5,0 kW 400 V 3	Latent heat emission:	2,04 kW
		Steam emission:	3,00 kg / h

Grilling surface: 490 x 410 mm
 Heating zones: 2x 2,5 kW
 Grill temperature infinitely adjustable using energy controller
 CNS flat heating elements can be swivelled upwards for cleaning the pan
 Fat collecting pan with drain plug
 Drain downwards, 40 mm diameter

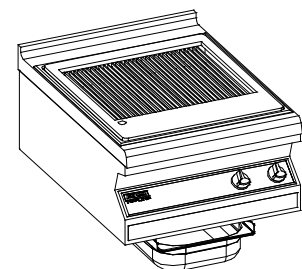

Accessories included:

- 1 x Appliance connection (696439)
- 1 x Drain plug (869961)
- 1 x Cleaning brush (864021)
- 1 x GN 1/1 Container 100 mm deep, with curved handles (609773)
- 1 x Perforated lid (615196)

☞ Use base cabinets of the TLGVB or UHVB-type !

Steak Grill 800 with drain on front side		Art. No.	Price EUR
Grilling directly on CNS flat heating elements for typical grill pattern		888577	
	Topline D	889274	
Dimensions (LxDxH):	800 x 800 x 320 / 355 mm	Direct heat emission:	2,82 kW
Connected load:	8,3 kW 400 V 3N	Latent heat emission:	3,43 kW
		Steam emission:	5,04 kg / h

Grilling surface: 684 x 410 mm
 Heating zones: 2
 1 x 4,7 kW
 1 x 3,6 kW

Grill temperature infinitely adjustable using energy controller
 CNS flat heating elements can be swivelled upwards for cleaning the pan
 Fat collecting pan with drain plug
 Drain on front side with safety valve

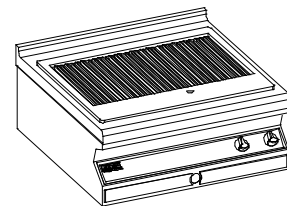

Accessories included: 1 x Appliance connection (696439)
 1 x Drain plug (869961)
 1 x Cleaning brush (864021)
 1 x Safety valve

Steak Grill 800 with drain downwards		Art. No.	Price EUR
Grilling directly on CNS flat heating elements for typical grill pattern		888583	
	Topline D	889276	
Dimensions (LxDxH):	800 x 800 x 320 / 355 mm	Direct heat emission:	2,82 kW
Connected load:	8,3 kW 400 V 3N	Latent heat emission:	3,43 kW
		Steam emission:	5,04 kg / h

Grilling surface: 684 x 410 mm
 Heating zones: 2
 1 x 4,7 kW
 1 x 3,6 kW

Grill temperature infinitely adjustable using energy controller
 CNS flat heating elements can be swivelled upwards for cleaning the pan
 Fat collecting pan with drain plug
 Drain downwards, 40 mm diameter

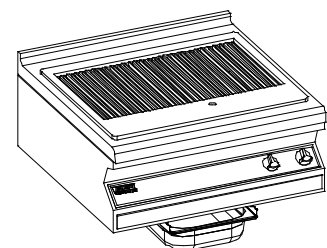

Accessories included: 1 x Appliance connection (696439)
 1 x Drain plug (869961)
 1 x Cleaning brush (864021)
 1 x GN 1/1 Container 100 mm deep, with curved handles (609773)
 1 x Perforated lid (615196)

☞ Use base cabinets of the TLGVB or UHVB-type !

Induction Pan		Art. No.	Price EUR
High-gloss polished stainless steel roasting grilling top / special composition of top with vacuum-soldered copper plate		876514	
	Topline D	889612	
Dimensions (LxDxH):	600 x 800 x 900 mm	Direct heat emission:	1,85 kW
Connected load:	8,0 kW 400 V 3	Latent heat emission:	2,24 kW
		Steam emission:	3,29 kg / h

Pan dimension: 530 x 569 x 75 mm
 Pan capacity: 21 Litres
 Cooking surface: 530 x 470 mm
 Heating zones: 2x 4,0 kW
 Range of temperature: 80 - 220°C
 With base cabinet in hygienic version H2

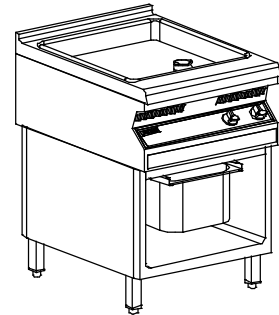

Accessories included:

- 1 x Appliance connection (696439)
- 1 x GN 1/1 - Container 200 mm deep, with curved handles (607207)
- 1 x Perforated lid (615196)
- 1 x Drain plug (502073)
- 1 x Cleaning scraper (614319)

Induction Wok		Art. No.	Price EUR
with Wok pan Ø 300 mm		877554	
	Topline D	889613	
Dimensions (LxDxH):	400 x 800 x 320 / 355 mm	Direct heat emission:	0,20 kW
Connected load:	5,0 kW 400 V 3N	Latent heat emission:	0,08 kW
		Steam emission:	0,12 kg / h

Wok capacity: 4.5 Litres

Accessories included:

- 1 x Appliance connection (696439)
- 1 x Wok Pan (692859)

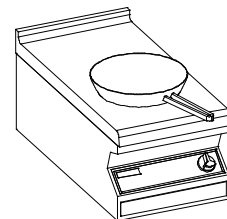

Induction Range 1		Art. No.	Price EUR
2 heating zones		877553	
	Topline D	889416	
Dimensions (LxDxH):	400 x 800 x 320 / 355 mm	Direct heat emission:	0,70 kW
Connected load:	10,0 kW 400 V 3	Latent heat emission:	0,28 kW
		Steam emission:	0,41 kg / h

Ceramic hob: 394 x 688 mm
 Heating zones: 2x 5.0 kW / Dimensions of coils: Ø 270 mm

Accessories included: 1 x Appliance connection (696439)

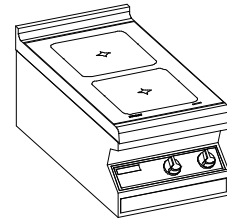

Induction Range 2		Art. No.	Price EUR
4 heating zones F		877556	
	Topline D		
Dimensions (LxDxH):	400 x 800 x 320 / 355 mm	Direct heat emission:	0,98 kW
Connected load:	14,0 kW 400 V 3	Latent heat emission:	0,39 kW
		Steam emission:	0,58 kg / h

Ceramic hob: 394 x 688 mm
 Heating zones: 4x 3.5 kW / Dimensions of coils: 260 x 135 mm

Accessories included: 1 x Appliance connection (696439)

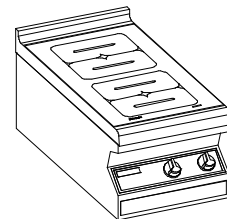

Induction Range 3		Art. No.	Price EUR
4 heating zones		877558	
	Topline D	889439	
Dimensions (LxDxH):	800 x 800 x 320 / 355 mm	Direct heat emission:	1,40 kW
Connected load:	20,0 kW 400 V 3	Latent heat emission:	0,56 kW
		Steam emission:	0,83 kg / h

Ceramic hob: 794 x 688 mm
 Heating zones: 4x 5.0 kW / Dimensions of coils: Ø 270 mm

Accessories included: 1 x Appliance connection (696439)

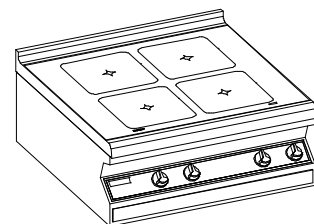

Induction Range 4		Art. No.	Price EUR
2 / 4 heating zones F		877560	
	Topline D	889523	
Dimensions (LxDxH):	800 x 800 x 320 / 355 mm	Direct heat emission:	1,68 kW
Connected load:	1 x 10,0 + 1 x 14,0 (24,0) kW 400 V 3	Latent heat emission:	0,67 kW
		Steam emission:	0,99 kg / h

Ceramic hob: 794 x 688 mm
 Heating zones: 2x 5.0 kW / Dimensions of coils: Ø 270 mm
 Heating zones: 4x 3.5 kW / Dimensions of coils: 260 x 135 mm

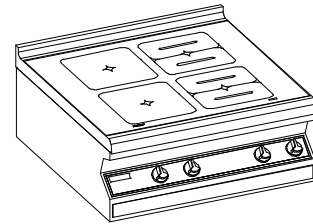

Accessories included: 1 x Appliance connection (696439)

Induction Range 4F		Art. No.	Price EUR
8 heating zones F		887796	
	Topline D	889638	
Dimensions (LxDxH):	800 x 800 x 320 / 355 mm	Direct heat emission:	1,96 kW
Connected load:	2x14,0 (28,0) kW 400 V 3	Latent heat emission:	0,79 kW
		Steam emission:	1,40 kg / h

Ceramic hob: 794 x 688 mm
 Heating zones: 8x 3,5 kW / Dimensions of coils: 260 x 135 mm

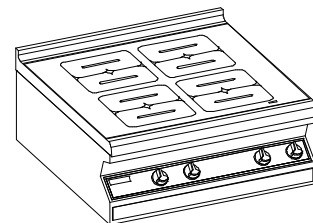

Accessories included: 1 x Appliance connection (696439)

Induction Range 5		Art. No.	Price EUR
2 heating zones crosswise and storage space in the rear area		877561	
	Topline D	889616	
Dimensions (LxDxH):	800 x 800 x 320 / 355 mm	Direct heat emission:	0,70 kW
Connected load:	10,0 kW 400 V3	Latent heat emission:	0,28 kW
		Steam emission:	0,41 kg / h

Ceramic hob: 794 x 688 mm
 Heating zones: 2x 5.0 kW / Dimensions of coils: Ø 270 mm

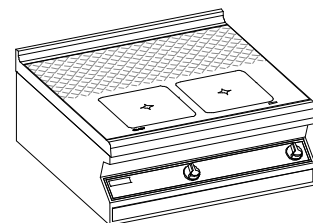

Accessories included: 1 x Appliance connection (696439)

Electric Baking Oven GN 1 1/2		Art. No.	Price EUR
as base cabinet		638625	
Dimensions (LxDxH):	800 x 745 x 430 mm	Direct heat emission:	1,61 kW
Connected load:	4,6 kW 400 V 3N	Latent heat emission:	0,74 kW
		Steam emission:	1,08 kg / h

Interior dimensions of oven: 535 x 520 x 250 mm

Accessories included: 1 x enamelled baking tray GN 1 1/2 (649716)
1 x CNS grate GN 1 1/2 (281131)

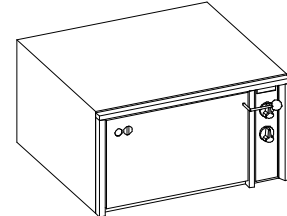

☞ It is possible to use a baking oven underneath any kind of range or work top.

Vario Gas Pan		Art. No.	Price EUR
Highly polished CNS frying/grilling top / with standard base cabinet / CE Id.-Nr. 0085 CN0057		836699	
Dimensions (LxDxH):	600 x 800 x 750 / 950 mm	Direct heat emission:	3,5 kW
Load:	10,0 kW natural gas E	Latent heat emission:	4,00 kW
		Steam emission:	5,88 kg / h

Pan dimension: 530 x 569 x 75 mm
Pan capacity: 21Litres
Cooking surface: 530 x 470 mm
Heating zones: 2x 5,0 kW
Range of temperature: 100 - 250°C
With standard base cabinet: 600 x 710 x 430 mm

Accessories included: 1 x Appliance connection (696439)
1 x GN 1/1 - container 200 mm deep, with curved handles (607207)
1 x Perforated lid (615196)
1 x Drain plug (502073)
1 x Cleaning scraper (614319)

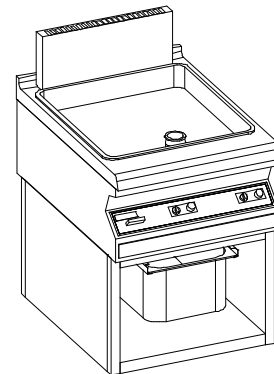

☞ Nozzle kit for natural gas LL has to be ordered separately if required (no extra charge).

Vario Gas Grill Pan		Art. No	Price EUR
Special steel plate, corrugated gradient / with standard base cabinet / CE Id.-Nr. 0085 CN0057		884500	
Dimensions (LxDxH):	600 x 800 x 750 / 950 mm	Direct heat emission:	3,50 kW
Load:	10,0 kW natural gas E	Latent heat emission:	4,00 kW
		Steam emission:	5,88 kg / h

- Cooking surface: 530 x 465 mm
- Heating zones: 2x 5,0 kW
- Range of temperature: 100 - 250°C
- With standard base cabinet: 600 x 710 x 430 mm
- Accessories included:
 - 1 x Appliance connection (696439)
 - 1 x GN 1/1 - container 200 mm deep, with curved handles (607207)
 - 1 x Perforated lid (615196)
 - 1 x Drain plug (502073)
 - 1 x Cleaning brush (614319)
 - 1 x Cleaning scraper (727563)

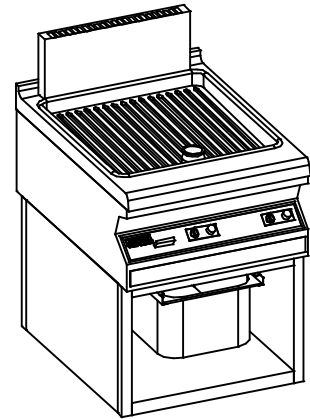

☞ Nozzle kit for natural gas LL has to be ordered separately if required (no extra charge).

Gas Grill 600		Art. No	Price EUR
Grid made of special cast iron, with H2 hygienic base cabinet / CE Id.-Nr. 0085 BR0418		889193	
Dimensions (LxDxH):	600 x 800 x 750 / 900 mm	Direct heat emission:	3,61 kW
Load:	10,3 kW natural gas E	Latent heat emission:	4,12 kW
		Steam emission:	6,06 kg / h

Grilling surface: 500 x 468 mm
 Heating zones: 2x 5,15 kW
 Base cabinet: H2 hygienic base (600 x 710 x 430 mm)
 Removable grease trap/water drawer

Accessories included: 1 x Appliance connection (696439)

☞ Nozzle kit for natural gas LL has to be ordered separately if required (no extra charge).

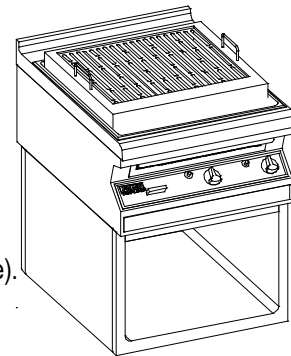

Gas Grill 800		Art. No	Price EUR
Grid made of special cast iron, with H2 hygienic base cabinet / CE Id.-Nr. 0085 BR0418		889194	
Dimensions (LxDxH):	800 x 800 x 750 / 900 mm	Direct heat emission:	5,42 kW
Load:	15,4 kW natural gas E	Latent heat emission:	6,18 kW
		Steam emission:	9,09 kg / h

Grilling surface: 700 x 468 mm
 Heating zones: 3x 5,15 kW
 Base cabinet: H2 hygienic base (800 x 710 x 430 mm)
 Removable grease trap/water drawer

Accessories included: 1 x Appliance connection (696439)

☞ Nozzle kit for natural gas LL has to be ordered separately if required (no extra charge).

Gas Lava Stone Grill 600		Art. No	Price EUR
Grid made of stainless steel rods, with H2 hygienic base cabinet / CE Id.-Nr. 0085 BR0418		889011	
Dimensions (LxDxH):	600 x 800 x 750 / 900 mm	Direct heat emission:	3,61 kW
Load:	10,3 kW natural gas E	Latent heat emission:	4,12 kW
		Steam emission:	6,06 kg / h

Grilling surface: 480 x 425 mm
 Heating zones: 2x 5,15 kW
 Base cabinet: H2 hygienic base (600 x 710 x 430 mm)
 Removable grease trap/water drawer

Accessories included: 1 x Appliance connection (696439)

☞ Nozzle kit for natural gas LL has to be ordered separately if required (no extra charge).

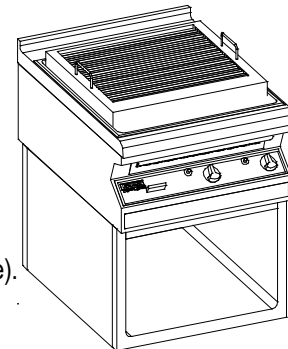

Gas Lava Stone Grill 800		Art. No	Price EUR
Grid made of stainless steel rods, with H2 hygienic base cabinet / CE Id.-Nr. 0085 BR0418		889085	
Dimensions (LxDxH):	800 x 800 x 750 / 900 mm	Direct heat emission:	5,42 kW
Load:	15,4 kW natural gas E	Latent heat emission:	6,18 kW
		Steam emission:	9,09 kg / h

Grilling surface: 689 x 425 mm
 Heating zones: 3x 5,15 kW
 Base cabinet: H2 hygienic base (800 x 710 x 430 mm)
 Removable grease trap/water drawer

Accessories included: 1 x Appliance connection (696439)

☞ Nozzle kit for natural gas LL has to be ordered separately if required (no extra charge).

Gas Hot Plate		Art. No	Price EUR
Cooking surface 25 mm enhanced / with standard base cabinet / CE Id.-Nr. 0085 CN0057		836788	
Dimensions (LxDxH):	800 x 800 x 750 / 1100 mm	Direct heat emission:	3,84 kW
Load:	12,0 kW natural gas E	Latent heat emission:	1,56 kW
		Steam emission:	2,29 kg / h

Cooking surface: 651 x 617 mm
 Heating zones: 2x 6,0 kW
 Range of temperature: 100 - 450°C
 With standard base cabinet: 800 x 710 x 430 mm
 On front side 2 atmospherical circular burners

Accessories included: 1 x Appliance connection (696439)

- ☞ No baking oven available!
- ☞ Nozzle kit for natural gas LL has to be ordered separately if required (no extra charge).

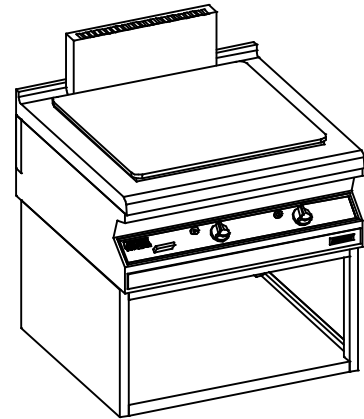

2-Burner Gas Range		Art. No.	Price EUR
With CNS sliding grill / CE Id.-Nr. 0085 CN0056		800163	
Dimensions (LxDxH):	400 x 800 x 320 / 355 mm	Direct heat emission:	3,00 kW
Load:	12,0 kW natural gas E	Latent heat emission:	1,20 kW
		Steam emission:	1,76 kg / h

Cooking surface: 370 x 700 mm
 Heating zones: 2, 1x 5,0 kW and 1 x 7,0 kW

Accessories included: 1 x Appliance connection (696439)

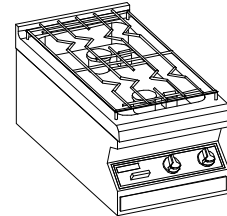

☞ Nozzle kit for natural gas LL has to be ordered separately if required (no extra charge).

4-Burner Gas Range		Art. No.	Price EUR
With CNS sliding grill / CE Id.-Nr. 0085 CN0056		800171	
Dimensions (LxDxH):	800 x 800 x 320 / 355 mm	Direct heat emission:	6,00 kW
Load:	24,0 kW natural gas E	Latent heat emission:	2,40 kW
		Steam emission:	3,53 kg / h

Cooking surface: 2 x 370 x 700 mm
 Heating zones: 4, 2x 5.0 kW and 2 x 7.0 kW

Accessories included: 1 x Appliance connection (696439)

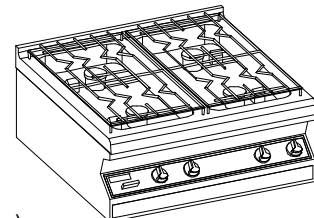

☞ Nozzle kit for natural gas LL has to be ordered separately if required (no extra charge).

Accessories Gas Hot Plate	Art. No.	Price EUR
Nozzle kit for liquid gas included	-	-
Nozzle kit for natural gas LL / for 2-burner Gas Range	699187	-
Nozzle kit for natural gas LL / for 4-burner Gas Range	699195	-
Nozzle kit for natural gas LL / for Vario Gas Pan & Vario Gas Grill Pan	846805	-
Nozzle kit for natural gas LL / for Gas Grill and Gas Lava Stone Grill	939749	-
Nozzle kit for natural gas LL / for Gas Hot Plate	858587	-
Flexible stainless steel hose DN 12, Length 2000 mm	730327	

Work tops

Work top 200	Art. No.	Price EUR
Dimensions (LxDxH): 200 x 800 x 320 / 355 mm	550329	

Work top 200 with swivelling top heater	Art. No.	Price EUR
without drawer	700673	
Dimensions (LxDxH): 200 x 800 x 320 / 355 mm Connected load: 0,6 kW 230 V 1 N AC	Direct heat emission: 0,12 kW Latent heat emission: 0,18 kW Steam emission: 0,24 kg / h	

Work top 200 with socket and earthing contact 230 V	Art. No.	Price EUR
without drawer		
Dimensions (LxDxH): 200 x 800 x 320 / 355 mm	810827	

Work top 200 with CEE-socket 400 V	Art. No.	Price EUR
without drawer		
Dimensions (LxDxH): 200 x 800 x 320 / 355 mm	810835	

Work top 400	Art. No.	Price EUR
Dimensions (LxDxH): 400 x 800 x 320 / 355 mm	888925	

Work top 400 with drawer GN 1/1	Art. No.	Price EUR
Dimensions (LxDxH): 400 x 800 x 320 / 355 mm	703001	

Work top 600 with drawer	Art. No.	Price EUR
Dimensions (LxDxH): 600 x 800 x 320 / 355 mm	703060	

Work top 800	Art. No.	Price EUR
Dimensions (LxDxH): 800 x 800 x 320 / 355 mm	540846	

Topline Black Edition in colour variation black front panel, painted graphite black RAL9011, for all thermal equipment available	Art. No.	Surcharge per worktop / unit EUR
Topline Black Edition - Length of appliance 200 mm	TL-BE-200	
Topline Black Edition - Length of appliance 400 mm	TL-BE-400	
Topline Black Edition - Length of appliance 600 mm	TL-BE-600	
Topline Black Edition - Length of appliance 800 mm	TL-BE-800	
Topline operating foil silver, replacement available for all units		
change standard foil into operating foil in silver	TL-BE-SB	No surcharge
Accessories Deep Fat Fryer	Art. No.	Price EUR
Rear bracket including installation at our factory	EHB621757	
Frying basket for Deep Fat Fryer Dimensions (LxDxH): 200 x 290 x 120 mm	271586	
1/2 Frying basket for Deep Fat Fryer Dimensions (LxDxH): 95 x 285 x 120 mm	275166	
Portion basket for Deep Fat Fryer Dimensions (LxDxH): 180 x 120 x 120 mm	374512	
Handle for swivel fixture - Version for adapter board no extra charge / only in connection with an adapter board	655895	-
Optimal Equipment Oil/Fat-Filter-Pump System	Art. No.	Price EUR
Oil/Fat-Filter-Pump System for single-pan deep-fat fryer with container and filter	FFPS1	
Oil/Fat-Filter-Pump System for dual-pan deep-fat fryer with container and filter	FFPS2	
☛ In case of using a Oil-/Fat-Filter-Pump System each deep-fat fryer a separate base cabinet with folding door (UHFT) is required.		
Accessories Chip Scuttle	Art. No.	Price EUR
GN 1/1 container - 200 mm deep	244414	
Perforated GN 1/1 insert, 200 mm deep	715808	
Perforated GN 1/1 insert, 2 sections, 200 mm deep	720739	

Accessories Vario Cooker	Art. No.	Price EUR
GN 1/3 container - 200 mm deep perforated on 4 sides and bottom Ø 4 mm, with folding handles	609935	
GN-P 1/3 container - 200 mm deep perforated Ø 3 mm (suitable for preparation of rice), with folding handles	649732	
GN 1/2 container - 200 mm deep perforated on 4 sides and bottom Ø 4 mm, with folding handles	609862	
Pasta basket, round Ø 170 mm	628042	
Pasta basket, round Ø 135 mm	628050	
Sieve, perforated, GN 1/1, with handles	648019	
Compartment insert (for 6 compartments)	930695	
Handle for swivel fixture - version for adapter board no extra charge / only in connection with an adapter board	655895	-
Accessories Pasta Cooker	Art. No.	Price EUR
Pasta basket with handle and bracket for automatic lifting baskets 280 x 200 x 200/300 mm	953431	
Pasta basket with handle and bracket for automatic lifting baskets 130 x 185 x 200/300 mm	955965	
Portion basket with handle 85 x 160 x 200/320 mm	956457	
Portion basket with handle (suitable 2 pieces for Art. No. 879 118) 85 x 115 x 200/320 mm	879117	
Pasta basket <u>without</u> handle, with bracket for automatic lifting baskets 130 x 185 x 200 mm	879118	
Accessories Vario Range	Art. No.	Price EUR
Splash guard for Vario Range 600	690503	
Splash guard for Vario Range 800	690511	
Accessories Steak Grill	Art. No.	Price EUR
Cleaning scrapper	051144	
GN 1/1 Container 100 mm deep, with curved handles (609 773)	609773	
Accessories Induction Wok	Art. No.	Price EUR
Wok Pan Ø 295 mm (included as standard equipment)	692859	

Accessories Vario Pan / Griddle Plate	Art. No.	Price EUR
GN 1/1 container - 200 mm deep with folding handles	607207	
Cover for GN 1/1 container with cut-out for GN 1/3 container	615196	
GN-P 1/3 container - 150 mm deep perforated (GN collecting container)	628565	
GN-P 1/3 container - 200 mm deep perforated (GN collecting container)	628573	
Cover for Vario Pan 400 / Vario Griddle Plate 400	502685	
Cover for Vario Pan 600 / Vario Griddle Plate 600	502693	
Cover for Vario Pan 800	892563	
Care emulsion	883277	
Splash guard for Vario Pan 400 and Vario Griddle Plate 400	628085	
Splash guard for Vario Pan 600, / Vario Griddle Plate 600 and Vario Grill Pan	628093	
Splash guard for Vario Pan 800 CC and Vario Pan 800 SC	881111	
Cleaning brush	614319	
Spatula	647187	
 spatula (Art. No. 647187)		
Accessories Kettle	Art. No.	Price EUR
Cooking insert, 2 parts, 2 sections, perforation 8 mm Dimensions: Ø 565 - 300 mm high	690554	
Cooking insert, 2 parts, 2 sections, perforation 2.5 mm Dimensions: Ø 565 - 300 mm high	690562	
1 pair of lifting hooks for cooking inserts	750867	
1 ring support for cooking inserts	690546	
Accessories Baking Oven	Art. No.	Price EUR
Grill GN 1 1/2 made of CNS	281131	
Enameled baking tray GN 1 1/2	649716	

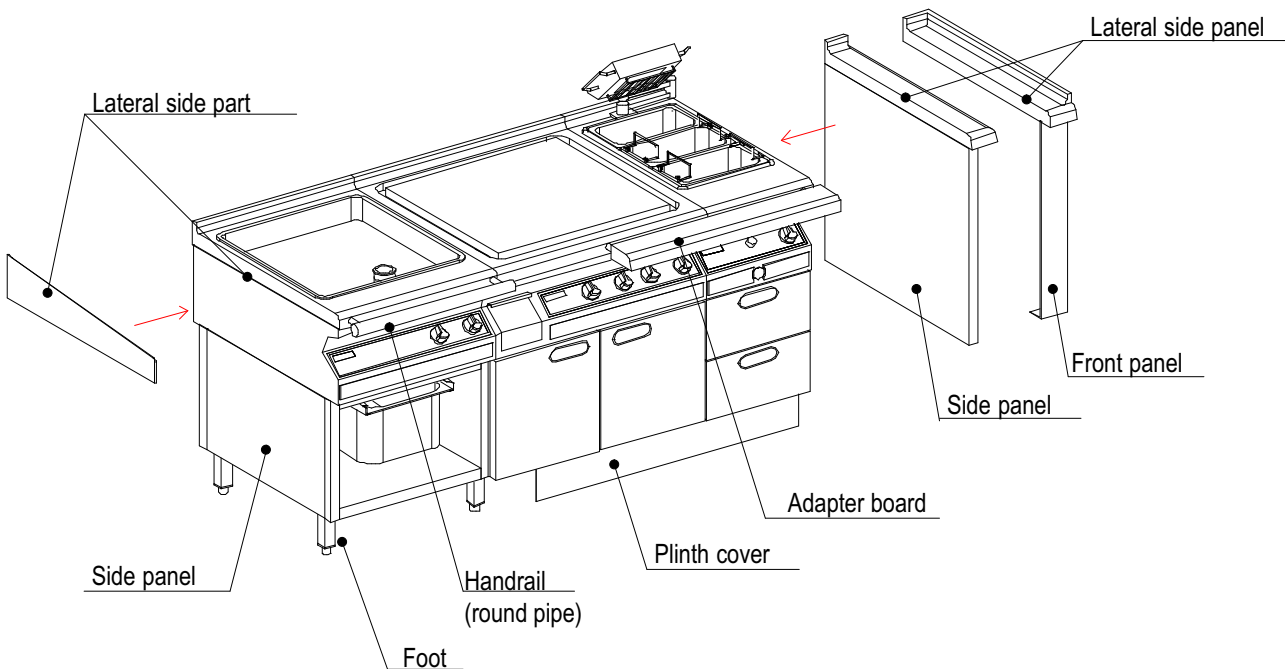

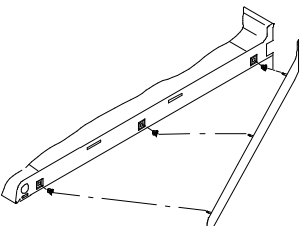

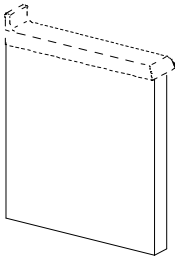
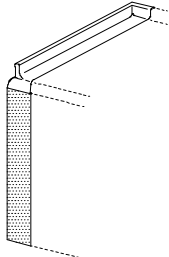
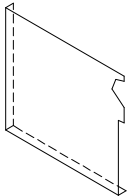
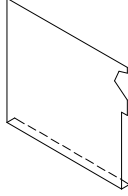
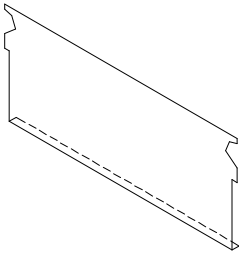
Lateral side part	Art. No.	Price EUR
 <p>Depth 800 mm</p>	Lateral side part, left	539589
	Lateral side part, right	539597
	Lateral side part, left for Ceramic- and Induction Ranges	808970
	Lateral side part, right for Ceramic- and Induction Ranges	808989
	Lateral side part, left folding up, 35 mm high	680818
	Lateral side part, right for Ceramic- and Induction Ranges folding up, 35 mm high	680826
	Lateral side part, left for Ceramic- and Induction Ranges folding up, 35 mm high	890079
	Lateral side part, right for Ceramic- and Induction Ranges folding up, 35 mm high	890077
	Lateral side part, left folding up, 40 / 100 mm high	680710
Lateral side part, right folding up, 40 / 100 mm high	680729	

Lateral side panel		Art. No.	Price EUR
	Lateral side panel, 100 mm, left radius design, folding down appliance connection included	528277	
	Lateral side panel, 100 mm, right radius design, folding down appliance connection included	528285	
	Side panel for appliances Dimensions (LxDxH) 32 x 785 x 700 mm	660337	
	Side panel for appliances (has to be used in combination with a lateral side panel).		
	Lateral side part, 100 mm, left radius design, folding up, appliance connection included	608262	
	Lateral side part, 100 mm, right radius design, folding up, appliance connection included	608270	
	Front panel Dimensions (LxH): 100 x 700 mm Kit lateral side part only possible with side wall	679682	
	Side panel with Topline-contour for wall assembly / Depth 800 mm Side panel left	730432	
	Side panel right	730858	
	Side panel with Topline-contour for line assembly / Depth 800 mm Side panel left	731900	
	Side panel right	732044	
	Side panel with Topline-contour for block assembly Side panel Depth 1600 mm	733024	
	Side panel Depth 1700 mm	733539	
	Side panel Depth 1800 mm	733873	

Installation versions for Topline Base Cabinets

Feet for Standard Base Cabinet TLG				
	Height	for depth 710 mm	Art. No.	Price EUR
	100 mm	Feet (2 pieces) on cross member for working height 850 mm	300600	
	150 mm	Feet (2 pieces) on cross member for working height 900 mm	300125	
	200 mm	Feet (2 pieces) on cross member for working height 950 mm	300606	

Castors for Standard Base Cabinet TLG				
	Height	for depth 710 mm	Art. No.	Price EUR
	150 mm	Castors (2 pieces) on cross member, one of them with locking break Diameter of castors 100 mm for working height 900 mm	302418	
	168 mm	Castors (2 pieces) on cross member, one of them with locking break Diameter of castors 125 mm for working height 918 mm	300611	

Feet for Base Cabinet Hygiene & Refrigeration				
	Height	for depth 710 mm	Art. No.	Price EUR
	100 mm	Foot (1 piece) for working height 850 mm	846864	
	150 mm	Foot (1 piece) for working height 900 mm	846872	
	200 mm	Foot (1 piece) for working height 950 mm	846880	
Without illustration	150 mm	Castors (4 pieces), two of them with locking break for working height 900 mm	EUFL	
Without illustration	100 mm	Foot (1 piece) for refrigeration for working height 850 mm	848336	
	150 mm	Foot (1 piece) for refrigeration for working height 900 mm	848344	
	200 mm	Foot (1 piece) for refrigeration for working height 950 mm	888236	

Plinth panel / plinth frame	Art. No.	Price EUR
Plinth panel Made of stainless steel / 150 mm high / installation not included	EUSK	per running metre
Plinth frame up to depth 800 / 838 mm Stainless steel 1,5 mm with reinforcing sections. height 150 mm	EUSR	Per running metre of the longest side

Optional feature - Mobile Base Cabinet	Art. No.	Price EUR
Optional feature "mobile", with steering rollers, for base cabinet of 600 mm length rollers-Ø 125 mm, incl. rear panel and cable suspension, working height 913 mm	ZMFLUG06	
Optional feature "mobile", with steering rollers, for base cabinet of 800 mm length rollers-Ø 125 mm, incl. rear panel and cable suspension, working height 913 mm	ZMFLUG08	
Optional feature "mobile", with steering rollers, for base cabinet of 1000 mm length rollers-Ø 125 mm, incl. rear panel and cable suspension, working height 913 mm	ZMFLUG10	
Optional feature "mobile", with steering rollers, for base cabinet of 1200 mm length rollers-Ø 125 mm, incl. rear panel and cable suspension, working height 913 mm	ZMFLUG12	

Connecting plug	Art. No.	Price EUR
Connecting plug CEE 400 V 16 A, cable 3000 mm included extra charge per appliance	ASTK3	
Connecting plug CEE 400 V / 32 A, cable 3000 mm included Extra charge per appliance	ASTK4	

Appliance Connection	Art. No.	Price EUR
Appliance connection 1 piece per unit as standard included	696439	

Side panel	Art. No.	Price EUR
Side panel for wall set-up for base cabinets UG (will be delivered if required according to the installation plan)	719242	-
Side panel for wall set-up for base cabinet UH (will be delivered if required according to the installation plan)	925438	-

Adapter Board						
Illustration	Depth 150 mm			Depth 200 mm		
	Length mm	Art. No.	Price EUR	Length mm	Art. No.	Price EUR
<p>Depth 150 mm</p> <p>Depth 200 mm</p>	400	ZAVB0415		400	ZAVB0420	
	600	ZAVB0615		600	ZAVB0620	
	800	ZAVB0815		800	ZAVB0820	
	1000	ZAVB1015		1000	ZAVB1020	
	1200	ZAVB1215		1200	ZAVB1220	
	1400	ZAVB1415		1400	ZAVB1420	
	1600	ZAVB1615		1600	ZAVB1620	
	1800	ZAVB1815		1800	ZAVB1820	
	2000	ZAVB2015		2000	ZAVB2020	
	2200	ZAVB2215		2200	ZAVB2220	
	2400	ZAVB2415		2400	ZAVB2420	
	2600	ZAVB2615		2600	ZAVB2620	
	2800	ZAVB2815		2800	ZAVB2820	
	3000	ZAVB3015		3000	ZAVB3020	
	3200	ZAVB3215		3200	ZAVB3220	
	3400	ZAVB3415		3400	ZAVB3420	
	3600	ZAVB3615		3600	ZAVB3620	

Handrail	Art. No.	Price EUR
Handrail (round pipe) Ø 40 mm / Total Depth 100 mm with protective cap Basic price (up to 1000 mm in length)	ZFHLGP	
Extra charge per running metre (of more than 1000 mm in length)	ZFHLLFM	

When choosing the version with adapter board / handrail, additional handles for swivel fixture have to be ordered for Vario Cooker and Deep Fat Fryer.

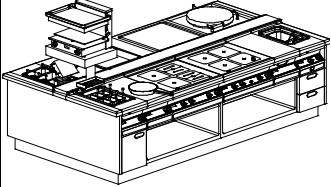
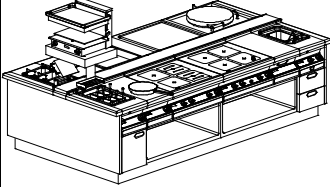
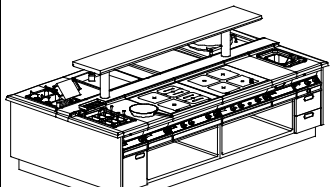
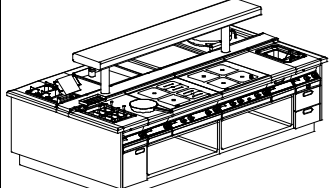
Board on Column	Art. No.	Price EUR
	<p>Salamander shelf Placed on work top 200 mm or Middle cover ZMMA24</p> <p>Dimension of Board (LxDxH): 520 x 500 x 100 mm Column Ø 102 mm / Height 400 mm Total height: 500 mm</p>	<p>ODBS50</p>
	<p>Salamander shelf - square column Placed on work top 200 mm or Middle cover ZMMA24</p> <p>Dimension of Board (LxDxH): 520 x 500 x 100 mm Square column with (LxDxH): 100 x 100 x 400 mm Total height: 500 mm</p>	<p>ODBS50-Q</p>
	<p>Board on column Placed on Middle cover ZMMA24</p> <p>Board Height: 50 mm / Total height 450 mm Depth: 450 mm - all sides folding down - radiused lower longitudinal sides - bottom side closed</p> <p>Column - round pipe Ø 102 mm Boards of >2600 mm require 3 columns</p> <p>Column - Square pipe 100 mm x 100 mm Boards of >2600 mm require 3 columns</p>	<p>EOBS1</p> <p>price per running metre</p> <p>EOSR</p> <p>price per column</p> <p>EOSV</p> <p>price per column</p>
	<p>Board on column Placed on Middle cover ZMMA24</p> <p>Board Height: 100 mm / Total height 500 mm Depth: 450 mm - all sides folding down - radiused on longitudinal sides - bottom side closed</p> <p>Column - round pipe Ø 102 mm Boards of >2600 mm require 3 columns</p> <p>Column - Square pipe 100 mm x 100 mm Boards of >2600 mm require 3 columns</p>	<p>EOBS2</p> <p>price per running metre</p> <p>EOSR</p> <p>price per column</p> <p>EOSV</p> <p>price per column</p>

Support for a Mixer

- for installation into worktops of 200 or 400 mm Length or into central cover of 240 mm Length

Description	Art. No.	Price EUR
Support for mixer, socket and mixing tap consisting of: 1x column 150 x 150 x 250 / 740 mm 1x socket 230V 1x bracket for mixer and cup (incl. cup) 1x connection for mixing tap 1x KWC-one lever mixing tap 2/4" with drip-stop, Height 490 mm, spout projektion 300 mm	SMS1000	
Support for mixer, socket and mixing tap consisting of: 1x column 150 x 150 x 250 / 740 mm 2x socket 230 V 2x bracket for mixer and cup (incl. cup) 1x connection for mixing tap 1x KWC-one lever mixing tap 2/4" with drip-stop Height 490 mm, spout projection 300 mm	SMS2000	



Illustration
Type SMS2000

- for installation into worktops of 200 or 400 mm or into central cover of 140 mm Length

Description	Art. No.	Price EUR
Support for mixer and socket consisting of: 1x column 150x150x250 mm 2x socket 230 V 2x bracket for mixer and cup (incl. cup)	SMS3	

Description	Art. No.	Price EUR
Support for mixer for installation on upper shelf for Salamander 1x bracket for mixer and cup (incl. cup)	MBH1	

Splash guard

Note for splash guard and partition wall: an installed splash guard / partition wall for deep fat fryers is according to DGUV 110-003 necessary for safety reasons if the distance between the deep fat fryer and water of any kind is less than 800 mm.

Item	Art. No.	Product code	Price EUR
Splash guard - for mounting on worktop and wall - bevelled on front side			
Dimensions: 2 x 670 x 350 mm	878659	SS-TOP-670	
Dimensions: 2 x 770 x 350 mm	878660	SS-TOP-770	

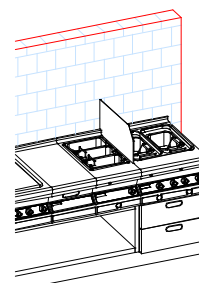

Item	Art. No.	Product code	Price EUR
Splash guard - for mounting on worktop - bevelled on front and rear side			
Dimensions: 2 x 650 x 350 mm	878661	SS-TG-650	
Dimensions: 2 x 750 x 350 mm	879236	SS-TG-750	

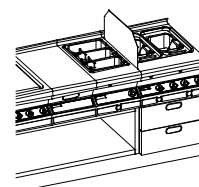

Partition wall

Note for splash guard and partition wall: an installed splash guard / partition wall for deep fat fryers is according to DGUV 110-003 necessary for safety reasons if the distance between the deep fat fryer and water of any kind is less than 800 mm.

Item	Art. No.	Product code	Price EUR
Partition wall - for mounting on worktop and wall - bevelled on front side			
Dimensions: 20 x 670 x 350 mm	878662	TW-TOP-670	
Dimensions: 20 x 770 x 350 mm	878663	TW-TOP-770	

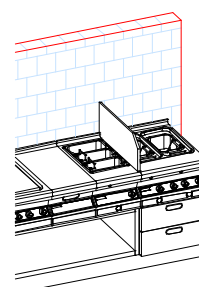

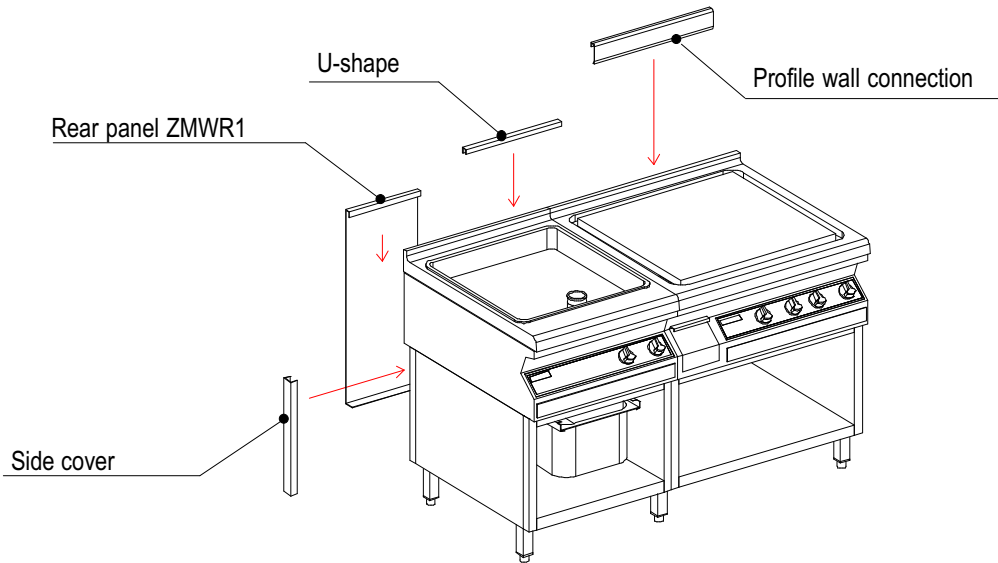

Accessories Line Assembly	Art. No.	Price EUR
Side cover (for wall assembly) U-shape 41 x 430 mm	679704	
U-shape / Price per running metre to cover the radius (folding up) / extra charge per running metre	ZMWU	
Profile wall connection, Height: 65 mm / Price per running metre as an additional folding up at the rear / extra charge per running metre	ZMWP01	
Profile wall connection, Height: 265 mm / Price per running metre as an additional folding up at the rear / extra charge per running metre	ZMWP02	
Profile wall connection, Height: 65 - 265 mm / Price per running metre as an additional folding up at the rear / extra charge per running metre	ZMWP03	
Extra charge for Profile wall connection closed on 1 side price per side	ZMWPG	
Rear panel / price per running metre to suspend from the folding up / extra charge per running metre	ZMWR1	
Rear panel - radius design / price per running metre to be adopted to work top shape 02 Depth: 38 mm, Height: 700 / 735 mm to suspend from the folding up / extra charge per running metre	ZMWR2	
Rear panel usable as storage surface 100 mm / price per running metre for installation of mixing valve, cough protection etc. Depth: 100 mm, Height: 700 / 735 mm to suspend from the folding up / extra charge per running metre	ZMWR3	

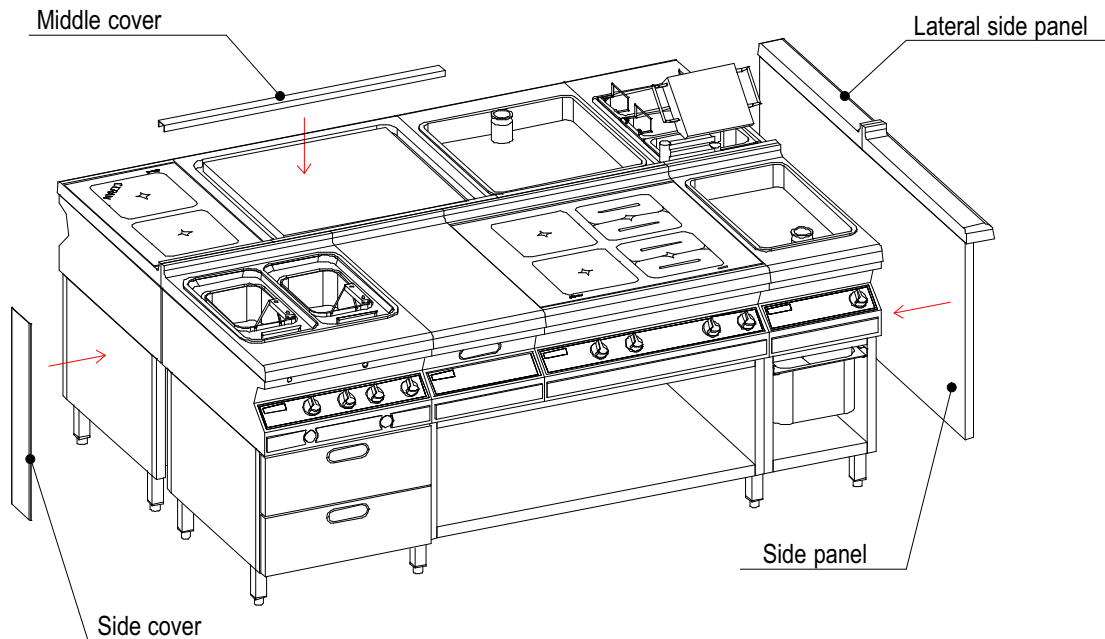

Accessories Block Assembly	Art. No.	Price EUR
Side cover 146 x 700 mm (standard)	EUBA1	
Side cover 246 x 700 mm (for assembly when using the middle cover ZMMA14)	EUBA2	
Side cover 346 x 700 mm (for assembly when using the middle cover ZMMA24)	EUBA3	
Middle cover, Depth 40 mm Extra charge per running metre	ZMMA04	
Middle cover, Depth 140 mm (Depth of kitchen block 1700 mm) Extra charge per running metre	ZMMA14	
Middle cover, Depth 240 mm (Depth of kitchen block 1800 mm) Extra charge per running metre	ZMMA24	
Side panel (Depth of kitchen block 1600 mm) Dimensions (LxDxH): 32 x 1570 x 700 mm only usable when using lateral side panels	662089	
Side panel (Depth of kitchen block 1700 mm) Dimensions (LxDxH): 32 x 1670 x 700 mm only usable when using lateral side panels	662097	
Side panel (Depth of kitchen block 1800 mm) Dimensions (LxDxH): 32 x 1770 x 700 mm only usable when using lateral side panels	662100	

Type			Function		Length		Corpus	Version
1	2	3	4	5	6	7	8	9
TLG= Base cabinet Appliances			OS= Closed on three sides FT= Folding door(s) SB= Block of drawers MA= Garbage container IF= Installation cabinet+folding door IB= Installation cabinet + front panel GN= GN-slides VB= for Vario Pan WS= Heated cabinet + sliding doors WF= Heated cabinet + folding doors		02= 200 mm 04= 400 mm 06= 600 mm 08= 800 mm 10= 1000 mm 12= 1200 mm		Depth 71= 710 mm	<u>Door hinging</u> L= hinged on left side R= hinged on right side <u>Drawer combinations</u> 1= 1 drawer Depth 200 mm 2= 2 drawers Depth 150 / 150 mm
Type		Function		Length		Maschine/ Installation	Version	
1	2	3	4	5	6	7	8	
UG= Base cabinet Appliances		KE= Cooling element		12= 1200 mm		M= Cooling machine right I= Installation cabinet for connection to external cooling machine	1= folding door 2= 2 drawers for GN 1/1 container Height 100 / 100 mm	

Base cabinet closed on three sides TLGOS

- Base cabinet as self-supporting structure, top side closed
- Closed on three sides
- Hygiene floor shelf, on three sides 25 mm folding up with radii 10 mm
- Interior and exterior cabinet absolutely smooth
- Made from stainless steel 1.4301
- Height 430 mm

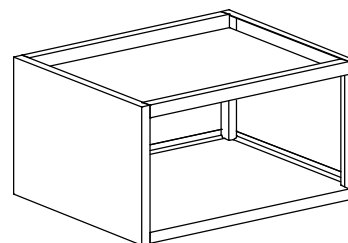

Depth 710 mm				
Length	Art. No.	Product Code	Dimensions interior (LxDxH)	Price EUR
400 mm	390130	TLGOS0471	342 x 709 x 353 mm	
600 mm	390131	TLGOS0671	542 x 709 x 353 mm	
800 mm	390132	TLGOS0871	742 x 709 x 353 mm	
1000 mm	390133	TLGOS1071	942 x 709 x 353 mm	
1200 mm	390134	TLGOS1271	1142 x 709 x 353 mm	

Base cabinet with folding door(s) TLGFT

- Base cabinet as self-supporting structure, top side closed
- Closed on four sides, with 1 or 2 double-walled insulated folding doors
- Folding door with magnetic door latch and recessed horizontal handle
- Radius upper and lower end
- Hygiene floor shelf, on three sides 25 mm folding up with radii 10 mm
- Interior and exterior cabinet absolutely smooth
- Made from stainless steel 1.4301
- Height 430 mm

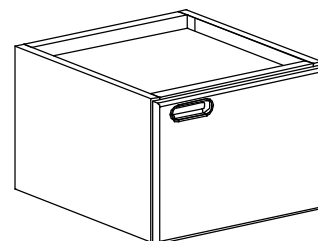

Depth 710 mm				
Length	Art. No.	Product Code	Number of doors / door hinging	Price EUR
400 mm	390293	TLGFT0471L	1 / left	
400 mm	390294	TLGFT0471R	1 / right	
600 mm	390295	TLGFT0671L	1 / left	
600 mm	390296	TLGFT0671R	1 / right	
800 mm	390297	TLGFT0871	2 / left + right	

Base cabinet with drawer(s) TLGSB

- Base cabinet as self-supporting structure, top side closed
- Removable box drawers with double-walled drawer cover and stainless steel telescopic rails
- Drawers with recessed horizontal handle
- Radius-design inside, on front and rear side
- Hygiene floor shelf, on three sides 25 mm folding up with radii 10 mm
- Interior and exterior cabinet absolutely smooth
- Made from stainless steel 1.4301
- Height 430 mm

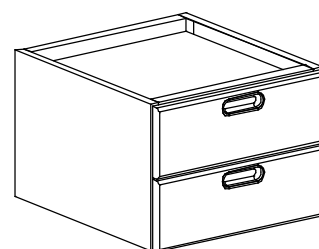

	Depth 710 mm			
Length	Art. No.	Product Code	Number of / Height of drawers	Price EUR
400 mm	390358	TLGSB04711	1 / 200 mm	
400 mm	390359	TLGSB04712	2 / 150 + 150 mm	
600 mm	390360	TLGSB06711	1 / 200 mm	
600 mm	390361	TLGSB06712	2 / 150 + 150 mm	

Base cabinet with garbage drawer TLGMA

- Base cabinet as self-supporting structure, top side closed
- Removable box drawer with garbage container and telescopic rails
- Double-walled drawer cover
- Drawer with recessed horizontal handle
- Hygiene floor shelf, on three sides 25 mm folding up with radii 10 mm
- Interior and exterior cabinet absolutely smooth
- Made from stainless steel 1.4301
- Height 430 mm

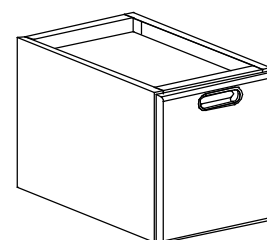

	Depth 710 mm			
Length	Art. No.	Product Code	Number of plastic containers	Price EUR
400 mm	390523	TLGMA0471	3 pcs. (each 13.2 litres; Art. No. 892278)	
600 mm	390524	TLGMA0671	3 pcs. (each 13.2 litres; Art. No. 892278)	

Base cabinet as installation cabinet with folding door TLGIF

- Base cabinet as self-supporting structure, top side closed
- Closed on four sides with double-walled folding door
- Folding door with magnetic door latch and recessed horizontal handle
- Cut-out in floor shelf and rear wall
- Hygiene floor shelf, on three sides 25 mm folding up with radii 10 mm
- Removable intermediate wall
- Interior and exterior cabinet absolutely smooth
- Made from stainless steel 1.4301
- Height 430 mm

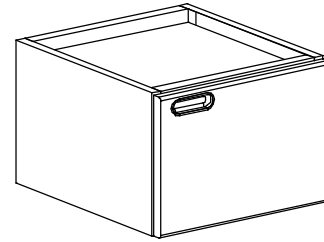

Depth 710 mm				
Length	Art. No.	Product Code	Door hinging	Price EUR
400 mm	390487	TLGIF0471L	left	
400 mm	390489	TLGIF0471R	right	
600 mm	390490	TLGIF0671L	left	
600 mm	390491	TLGIF0671R	right	
		Terminal box (Art. No. 909548) Dimensions (LxDxH): 300 x 300 x 130 mm For 9 cables Connections for energy management system For installation in installation cabinet 400 or 600 mm length		

Base cabinet with front panel TLGIB

- Base cabinet as self-supporting structure, top side opened
- Removable front panel, without floor shelf
- Interior and exterior cabinet absolutely smooth
- Made from stainless steel 1.4301
- Height 430 mm

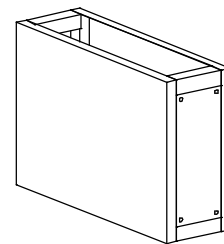

Depth 710 mm				
Length	Art. No.	Product Code	Socket for TLGIB	Price EUR
200 mm	390486	TLGIB0271		
-	EZSD23	-	230 V socket (incl. installation)	
-	EZCE40	-	400 V CEE socket (incl. installation)	

Base cabinet with GN slides TLGGN

- Base cabinet as self-supporting structure, top side closed
- Closed on three sides to insert GN 1/1 containers and trays
- Hygiene floor shelf, on three sides 25 mm folding up with radii 10 mm
- Interior and exterior cabinet absolutely smooth
- Made from stainless steel 1.4301
- Height 430 mm

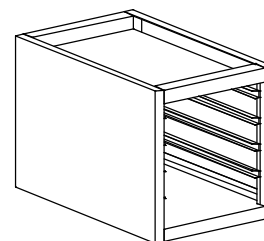

	Depth 710 mm			
Length	Art. No.	Product Code	Number of slides / Spacing	Price EUR
400 mm	390463	TLGGN0471	4 / 75 mm	

Base cabinet closed on three sides for Vario Pan TLGVB

- Base cabinet as self-supporting structure, top side closed
- Closed on three sides
- Base cabinet for drain containers Vario Pan
- Discharge opening on top side
- Hygienic floor shelf, bottom floor sideways and in rear with a radii 10 mm, 25 mm folding up
- Interior and exterior cabinet absolutely smooth
- Made from stainless steel 1.4301
- Height 430 mm

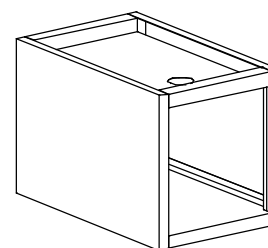

	Depth 710 mm			
Length	Art. No.	Product Code	Dimensions / combination	Price EUR
400 mm	391398	TLGVB0471	400	
600 mm	391399	TLGVB0671	600	
800 mm	391657	TLGVB0871	800	
1000 mm	391400	TLGVB1071	Combination of 400 and 600	

Base cabinet as heated cabinet with sliding doors TLGWT

- Base cabinet as self-supporting structure, top side closed, insulated on sides, rear and above
- Heated cabinet with circulating air, thermostatic temperature control up to 85°C
- Closed on four sides, double-walled sliding doors
- Sliding doors attached to the top, on ball bearings
- Insulated doors with recessed vertical handles
- Perforated floor shelf
- Recessed operation panel on right side
- Interior and exterior cabinet absolutely smooth
- Made from stainless steel 1.4301
- Height 430 mm

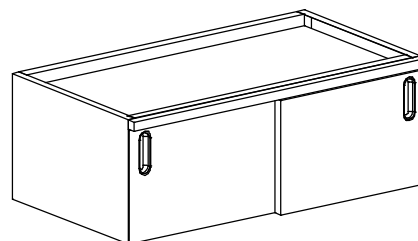

	Depth 710 mm			
Length	Art. No.	Product Code	Connected load	Price EUR
1200 mm	390625	TLGWT1271	1,5 kW 230 V 1N	

Base cabinet as heated cabinet with folding doors TLGWF

- Base cabinet as self-supporting structure, insulated, top side closed
- Heated cabinet with circulating air, thermostatic temperature control up to 85°C
- Closed on four sides, double-walled insulated folding doors with recessed horizontal handles
- Perforated floor shelf
- Radius on upper and lower end
- Recessed operation panel on right side
- Interior and exterior cabinet absolutely smooth
- Made from stainless steel 1.4301
- Height 430 mm

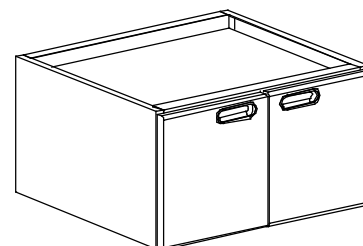

	Depth 710 mm			
Length	Art. No.	Product Code	Connected load	Price EUR
800 mm	391413	TLGWF0871	1,5 kW 230 V 1N	

Base cabinet refrigerated element 2xGN 1/1 with refrigeration machine UGKE-M

- Refrigeration machine on right side
- Circulating air refrigeration, temperature range -2 to +10° C
- CFC-free, 50 mm PU insulation
- Interior: hygienic version with deep-drawn floor shelf
- Static cooling system, evaporator foamed into rear wall, integrated drain channel
- Folding doors / drawers with recessed handles
- Drawers with radius at front and rear side
- Drawers for GN - containers of 100 mm height
- Electronic thermostat with digital display
- HACCP monitoring system
- Automatic defrost and evaporation of defrost water
- Accessories: 1 Rilsan coated grate per door
- Height 430 mm

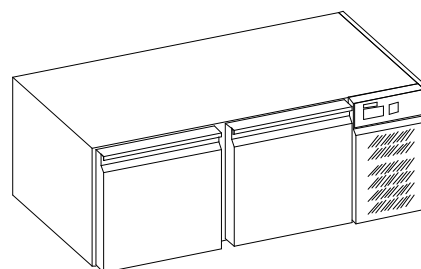

UGKE12M11

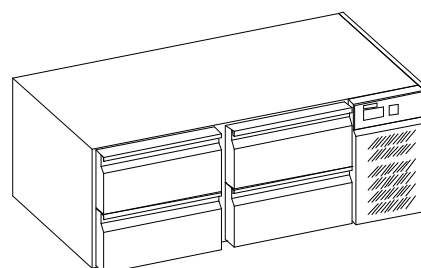

UGKE12M22

Gross contents: 145 Liter
Refrigeration capacity: 255 W at -15° C ET / +32° C AT
Refrigerant: R290
Connected load: 350 W 230 V 50 Hz
Consumption: 1,40 kWh / 24 h

Depth 675 mm				
Length	Art. No.	Folding doors / drawers	Usable volume	Price EUR
1200 mm	UGKE12M11 ¹⁾	2 x folding doors	96 l	
1200 mm	UGKE12M22 ¹⁾	2 x 2 drawers	79 l	

¹⁾ energy efficiency class B.

Base cabinet refrigerated element 2 x GN 1/1 with installation cabinet UGKE-I

- Installation compartment on right side
Connection of electric cables, refrigeration pipes and drain provided by customer
- Circulating air refrigeration, temperature range -2 to +10° C
- CFC-free, 50 mm PU insulation
- Interior: hygienic version with deep-drawn floor shelf
- Static cooling system, evaporator foamed into rear wall, integrated drain channel
- Doors / drawers with recessed handles
- Drawers inside with radius at the front and at the rear
- Drawers for GN - containers, 100 mm height
- Electronic thermostat with digital display
- HACCP monitoring system
- Automatic defrost dia of drain 16 mm
- Accessories: 1 Rilsan coated grate per door
- Expansion valve not included
- Height 430 mm

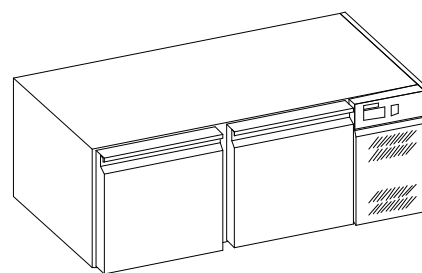

UGKE1211

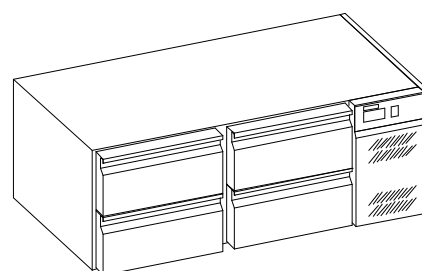

UGKE12122

Gross contents: 145 Liter
Refrigeration capacity: 200 W at -15° C ET / +32° C AT
Connected load: 80 W 230 V 50 Hz

	Depth 675 mm			
Length	Art. No.	Folding doors / drawers	Usable volume	Price EUR
1200 mm	UGKE12111	2 x folding doors	96 l	
1200 mm	UGKE12122	2 x 2 drawers	79 l	

Type		Function		Length		Corpus	Version	
1	2	3	4	5	6	7	8	
UH= Base cabinet Hygiene		OS= Open cabinet FT= Folding door SB= Block of drawers GN= Gastronorm MA= Garbage container VB= Vario Pan open cabinet		04= 400 mm 06= 600 mm 08= 800 mm 10= 1000 mm 12= 1200 mm		3= 710 mm	<u>Depth</u> 3= 710 mm	<u>Door stop</u> L= hinged on left side R= hinged in right side <u>Drawer combinations</u> 1= 1 drawer Depth 200 mm 2= 2 drawers Depth 150 / 150 mm

Base cabinet Hygiene closed on three sides UHOS

- Base cabinet as self-supporting structure
- Closed on three sides, with even side panels and even bottom
- Hygienic version H2, bottom and side panels welded, seamless, radius R19, attached cover
- End of side panels double-walled when there is no base cupboard next to it
- Height 430 mm

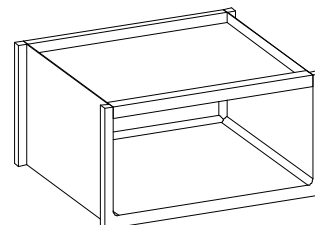

	Depth 710 mm			
Length	Art. No.	Product code	Dimensions interior (LxDxH)	Price EUR
400 mm	803790	UHOS043	336 x 699 x 350 mm	
600 mm	803804	UHOS063	536 x 699 x 350 mm	
800 mm	803812	UHOS083	736 x 699 x 350 mm	
1000 mm	803820	UHOS103	936 x 699 x 350 mm	
1200 mm	803839	UHOS123	1136 x 699 x 350 mm	

Base cabinet Hygiene with folding door(s) UHFT

- Base cabinet as self-supporting structure
- Completely closed on 4 sides, with 1 or 2 double-walled folding doors
- Folding door with magnetic door latch and recessed handle
- Hygienic version H2, bottom and side panels welded, seamless, radius R19, attached cover
- End of side panels double-walled when there is no base cupboard next to it
- Height 430 mm

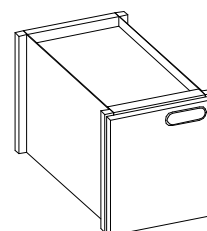

	Depth 710 mm			
Length	Art. No.	Product code	Number of doors / door hinging	Price EUR
400 mm	803847	UHFT043L	1 / left	
400 mm	803863	UHFT043R	1 / right	
600 mm	803855	UHFT063L	1 / left	
600 mm	803871	UHFT063R	1 / right	
800 mm	803898	UHFT083	2 / left and right	

Base cabinet Hygiene with drawer(s) UHSB

- Drawer block with removable drawers
- Drawer can be pulled out completely, rails made of stainless steel
- Radius design inside, at the front and at the rear
- Integrated, easy-to-clean handle recess
- Hygienic version H2, bottom and side panels welded, seamless, radius R19, attached cover
- End of side panels double-walled when there is no base cupboard next to it
- Height 430 mm

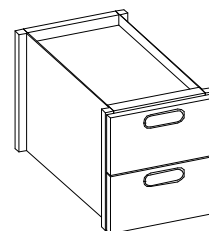

	Depth 710 mm			
Length	Art. No.	Product code	Number of drawers / height	Price EUR
400 mm	803901	UHSB0431	1 / 200 mm	
400 mm	803936	UHSB0432	2 / 150 + 150 mm	
600 mm	803928	UHSB0631	1 / 200 mm	
600 mm	803944	UHSB0632	2 / 150 + 150 mm	

Base cabinet Hygiene with GN slides UHGN

- Base cabinet as self-supporting structure
- Closed on three sides, open at the front to allow insertion of containers and trays GN 1/1
- Side panels with 5 GN-rails as bead stamping with tilting protection
- Hygienic version H2, bottom and side panels welded, seamless, radius R19, attached cover
- End of side panels double-walled when there is no base cupboard next to it
- Height 430 mm

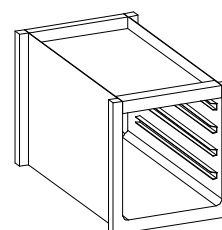

	Depth 710 mm			
Length	Art. No.	Product code	Number of rails / spacing	Price EUR
400 mm	803952	UHGN043	5 / 55 mm	

Base cabinet Hygiene with garbage container UHMA

- Base cabinet as self-supporting structure
- Removable drawer as garbage container
- Drawer can be pulled out completely, rails made of stainless steel
- Integrated, easy-to-clean handle recess
- Radius form (top and bottom)
- Hygienic version H2, bottom and side panels welded, seamless, radius R19, attached cover
- End of side panels double-walled when there is no base cupboard next to it
- Height 430 mm

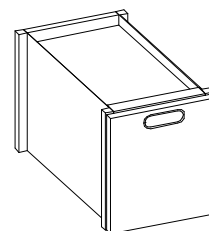

	Depth 710 mm			
Length	Art. No.	Product code	Number of plastic containers	Price EUR
400 mm	803960	UHMA043	3 pcs. 13,2 litres each (892278)	

Base cabinet Hygiene for Vario Pan UHVB

- Base cabinet as self-supporting structure
- Closed on three sides, with even side panels and even bottom
- In the base cabinet GN 1/1 insert for drainage for the Vario Pan
- On top drainage for Vario Pan
- Hygienic version H2, bottom and side panels welded, seamless, radius R19, attached cover
- End of side panels double-walled when there is no base cupboard next to it
- Height 430 mm

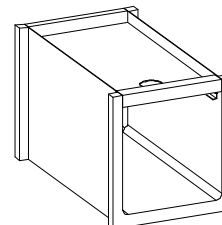

	Depth 710 mm			
Length	Art. No.	Product code	For Vario Pan	Price EUR
400 mm	803987	UHVB043	400	
600 mm	803995	UHVB063	600	
800 mm	804010	UHVB083	800	
1000 mm	804029	UHVB10346	400 (on the left) and 600 (on the right)	
1000 mm	804037	UHVB10364	400 (on the right) and 600 (on the left)	

Wall assembly	Room assembly
----------------------	----------------------

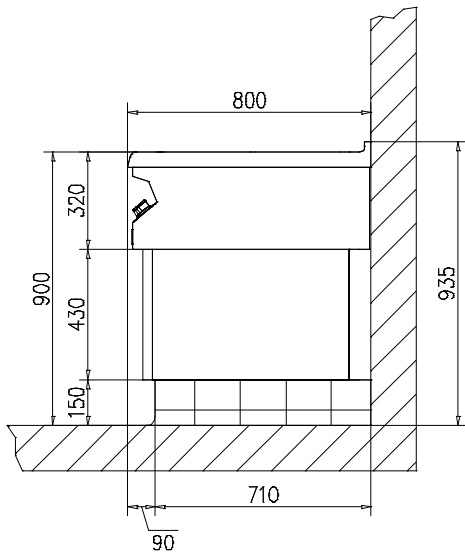

with ZMWR1 - rear panel as standard

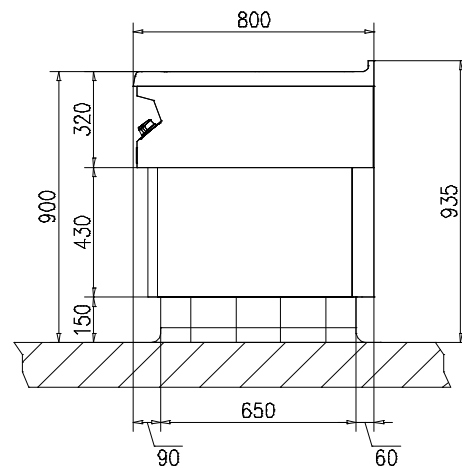

Foot or plinth assembly

Measurement base and drainage channel Vario Pan Plus

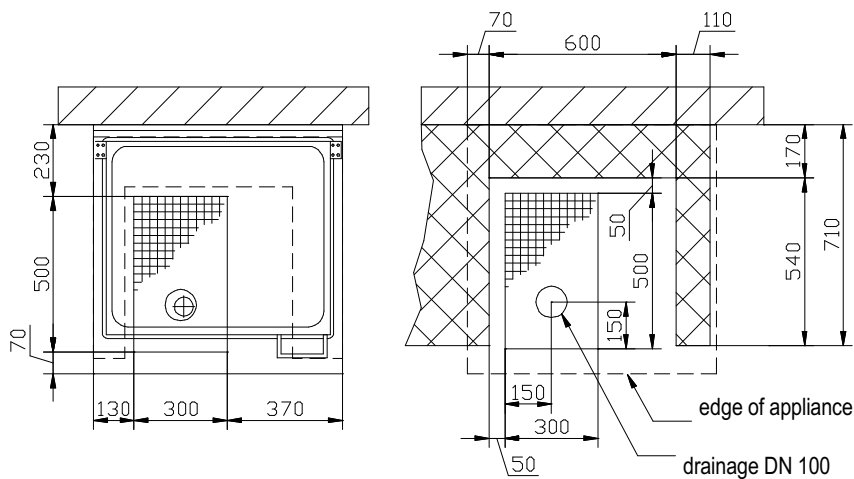

Stated dimensions block assembly

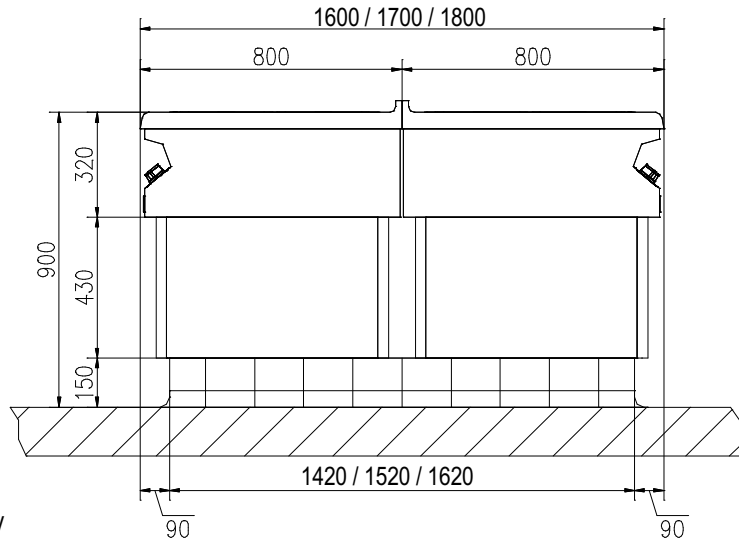

Foot or plinth assembly

General dimensions

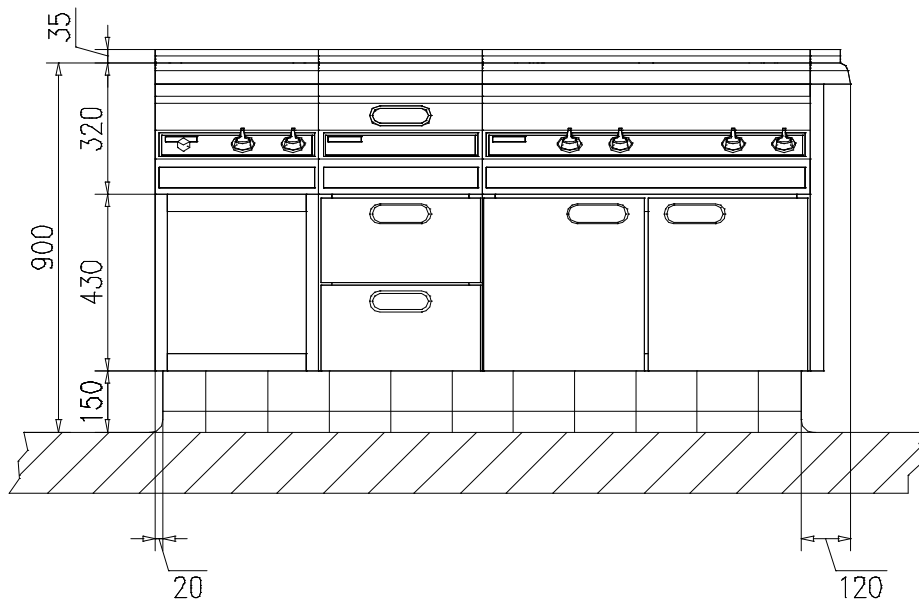

Electric



Designation	Art. No.	Topline D Art. No.	Length	kW	Heat emission kW		Steam emission
					direct	latent	
Single-Pan Deep Fat Fryer	649554	—	400 mm	8,0	0,72	5,60	8,24 kg/h
	879987	—					
	880006	—					
	880152	—					
	884861	—					
	884862	—					
	880007	—					
	880153	—					
	880008	—					
	880154	—					
Dual-Pan Deep Fat Fryer	649562	—	600 mm	2x 8,0	1,44	11,20	16,48 kg/h
	879965	—					
	880009	—					
	880158	—					
	884851	—					
	884852	—					
	880010	—					
	880160	—					
	880011	—					
	880161	—					
Chip Scuttle GN 1/1	659002	889585	400 mm	0,6	0,08	0,12	
Bain Marie GN 1/1	667412	889528	400 mm	2,0	0,25	0,40	0,59 kg/h
	140902	889529					
	879896	889530					
	879897	889531					
Bain Marie GN 2/1	684848	889532	800 mm	4,0	0,50	0,80	1,18 kg/h
	832995	889533					
	879898	889534					
	879899	889535					
Vario Cooker GN 1/1	503010	889565	400 mm	7,0	0,86	1,40	2,06 kg/h
	517887	889566					
	730610	889567					
	730629	889568					
with electric heater	657735	889569	400 mm	7,6	0,95	1,52	2,23 kg/h

Designation	Art. No.	Topline D Art. No.	Length	kW	Heat emission kW		Steam emission
					direct	latent	
Pasta Cooker GN 1/1	949590	889599	400 mm	7,0	0,86	1,40	2,06 kg/h
	949604	889600					
	953504	889601	600 mm	7,0	0,86	1,40	2,06 kg/h
	953512	889602					
Vario Pan 400	502650	889277	400 mm	4,8	1,27	1,54	2,26 kg/h
Vario Pan 600	502707	889279	600 mm	7,0	1,85	2,24	3,29 kg/h
Vario Pan CC Vario Pan SC	879316	889281	800 mm	10,5	2,77	3,36	4,93 kg/h
	880123	889282					
Vario Grill Pan	725315	889283	600 mm	10,0	3,30	4,00	5,88 kg/h
Vario Pan M	811084	889284	600 mm	10,0	2,64	3,20	4,70 kg/h
Vario Pan Plus	144819	–	800 mm	13,5	3,56	4,32	6,35 kg/h
Griddle Plate 400	879641	889286	400 mm	4,8	1,58	2,68	2,26 kg/h
Griddle Plate 600	879642	889287	600 mm	7,0	2,31	3,92	4,11 kg/h
Kettle	880980	–	800 mm	18,6	0,65	3,72	5,47 kg/h
Ceramic Range 1	733105	889604	400 mm	7,0	1,40	0,56	0,83 kg/h
Ceramic Range 2	733113	889605	800 mm	2x 7,0	2,80	1,12	1,65 kg/h
Vario Range 1	687200	889606	600 mm	7,0	1,40	0,56	0,83 kg/h
	703095	889608					
Vario Range 2	690600	889609	800 mm	2x 7,0	2,80	1,12	1,65 kg/h
	703109	889611					
Steak Grill 400	883931	889222	400 mm	3,6	1,19	1,44	2,12 kg/h
	883015	889245					
Steak Grill 600	883932	889248	600 mm	5,0	1,68	2,04	3,00 kg/h
	883016	889273					
Steak Grill 800	888577	889274	800 mm	8,3	2,82	3,40	5,04 kg/h
	888583	889276					
Induction Pan	876514	889612	600 mm	8,0	1,85	2,24	3,29 kg/h
Induction Wok	877554	889613	400 mm	5,0	0,20	0,08	0,12 kg/h
Induction Range 1	877553	889416	400 mm	10,0	0,70	0,28	0,41 kg/h
Induction Range 2	877556	889433	400 mm	2x 7,0	0,98	0,39	0,58 kg/h
Induction Range 3	877558	889439	800 mm	2x 10,0	1,40	0,56	0,83 kg/h
Induction Range 4	877560	889523	800 mm	10,0+14,0	1,68	0,67	0,99 kg/h
Induction Range 4F	887796	889638	800 mm	2x 14,0	1,96	0,79	1,40 kg/h
Induction Range 5	877561	889616	800 mm	10,0	0,70	0,28	0,41 kg/h
Electric Baking Oven GN 1 1/2	638625	–	800 mm	4,6	1,61	0,74	1,08 kg/h

Gas



Designation	Art. No.	Length	kW	Heat emission kW		Steam emission
				direct	latent	
Vario Gas Pan	836699	600 mm	10,0	3,50	4,00	5,88 kg/h
Vario Gas Grill Pan	884500	600 mm	10,0	3,50	4,00	5,88 kg/h
Gas Grill 600	889193	600 mm	10,3	3,61	4,12	6,06 kg/h
Gas Grill 800	889194	800 mm	15,4	5,42	6,18	9,09 kg/h
Gas Lava Stone Grill 600	889011	600 mm	10,3	3,61	4,12	6,06 kg/h
Gas Lava Stone Grill 800	889085	800 mm	15,4	5,42	6,18	9,09 kg/h
Gas Hot Plate	836788	800 mm	12,0	3,84	1,56	2,29 kg/h
2-Burner Gas Range	800163	400 mm	12,0	3,00	1,20	1,76 kg/h
4-Burner Gas Range	800171	800 mm	24,0	6,00	2,40	3,53 kg/h



PALUX Aktiengesellschaft
Wilhelm-Frank-Straße 36
97980 Bad Mergentheim
GERMANY
Telephone: +49 7931 55 0
Telefax: +49 7931 55 88600
Internet: www.palux.de
E-Mail: info@palux.de
Art. No. 700789 / 26.01.2023

PALUX

Das große Freiheit